

## F116 (Series 16000) Self-Contained Ductable Commercial Air Cleaner

### PRODUCT DATA



### FEATURES

- Variety of filter configurations available to customize the air cleaner for any application.
- Three-speed direct drive forward curve blower/motor circulates up to 2500 cfm (72 m<sup>3</sup>/min) for large areas.
- Negative and positive pressure rooms can be created with the air cleaner.
- Charcoal, permanganate and zeolite (CPZ™) disposable modules can be used for odor control.
- Two stage and three stage air cleaners are compatible with a wide range of applications.
- 120 Vac, 60 Hz models available.

### APPLICATION

The F116 (Series 16) Self-Contained Ductable Commercial Air Cleaner uses direct drive forward curve blower/motor with a variety of filter configurations to remove airborne contaminants. The air cleaner provides its own air circulation, so it can be used in any situation that requires the removal of contamination from an enclosed area. The air going to the unit and the discharged air may be transported by a network of ducting and plenums or the unit can be used independently.

### Contents

Application .....	1
Features .....	1
Specifications .....	2
Ordering Information .....	2
Planning the Installation .....	6
Installation .....	7
Service .....	12
Troubleshooting .....	15
Parts List .....	16
Warranty .....	18



## SPECIFICATIONS

### IMPORTANT

*The specifications given in this publication do not include normal manufacturing tolerances. Therefore, this unit may not exactly match the listed specifications. This product is tested and calibrated under closely controlled conditions, and some minor differences in performance can be expected if those conditions are changed.*

### Models:

The F116 (Series 16000) air cleaner is available in two cabinet sizes. The shorter cabinet uses a prefilter with one primary filter while the longer cabinet uses a prefilter with two primary filters. Refer to Table 1 for model descriptions.

### Construction:

.0508 in., 16 GA unpainted aluminum

### Blower/Motor:

- three speed direct drive forward curve
- 1070 RPM nominal speed
- thermal circuit breaker

NOTE: Oil annually.

### Electrostatic Precipitator Power Supply:

- regulated solid state
- 0.4A at 120V
- high voltage indicator light
- pressure switch activated (no air flow, no power supply voltage)
- cell performance indicator
- arcing control circuitry

### Static Pressure:

Minimum: 1.2" W.G.  
Maximum: 1.85" W.G.

Table 1. F116 (Series 16000) Description.

Model	Voltage	Filtering Stages	Contains	Suggested Applications
F116A1021 (16002)	120 Vac, 60 Hz, 1PHS, 0.4A	Two	1 prefilter and 1 HEPA filter	Medical isolation wards, industrial clean rooms and source capture of highly toxic particulates
F116A1047 (16004)	120 Vac, 60 Hz, 1PHS, 0.4A	Two	1 prefilter <sup>a</sup>	Any airborne particulate or gas/odor/VOC, but not in combination
F116A1120 (16012)	120 Vac, 60 Hz, 1PHS, 0.4A	Three	1 prefilter <sup>a</sup>	Any particulate and/or gas/odor/VOC
F116E1001 (16000)	120 Vac, 60 Hz, 1PHS, 0.4A	Two	1 prefilter and 2 electrostatic precipitator collecting cells	Any nonconductive airborne respirable particulate such as tobacco smoke, atmospheric dusts, brazing smoke and some oil smokes
F116E1100 (16010)	120 Vac, 60 Hz, 1PHS, 0.4A	Three	1 prefilter and 2 electrostatic precipitator collecting cells <sup>b</sup>	Any respirable particulate and gas/odor/VOC

<sup>a</sup> Primary filters must be ordered separately. The choices include a 95% D.O.P. filter, ASHRAE dust spot filter or two sorbent modules.

<sup>b</sup> Second primary filter must be ordered separately. The choices include a 95 % D.O.P. filter, ASHRAE dust spot filter or two sorbent modules.

## ORDERING INFORMATION

When purchasing replacement and modernization products from your TRADELINE® wholesaler or distributor, refer to the TRADELINE® Catalog or price sheets for complete ordering number.

If you have additional questions, need further information, or would like to comment on our products or services, please write or phone:

1. Your local Honeywell/EnviroNaire® Commercial Air Cleaner Distributor (check white pages of your phone directory).
2. Home and Building Control Customer Logistics  
Commercial Air Products  
Honeywell Inc., 1885 Douglas Drive North  
Minneapolis, Minnesota 55422-3992 (612) 954-6945

In Canada—Honeywell Limited/Honeywell Limitée, 155 Gordon Baker Road, North York, Ontario M2H 3N7.  
International Sales and Service Offices in all principal cities of the world. Manufacturing in Australia, Canada, Finland, France, Germany, Japan, Mexico, Netherlands, Spain, Taiwan, United Kingdom, U.S.A.

**Electrical Ratings:**

Running Load (all three fan speeds): must not exceed 14A at 120V.  
Refer to Table 2 for maximum starting loads.

**Filtration Efficiency:**

See Table 4.

**Power:**

Hardwire

**Approvals:**

UL and cUL pending.

**Dimensions:**

See Fig. 1 and 2 for dimensions.

**Replacement Parts and Accessories:**

See Parts List on page 16.

**Table 2. F116 (Series 16000) Maximum Starting Loads.**

Fan Setting	Voltage	Amperes
High	120V	23A
Medium	120V	15A
Low	120V	15A

**Air Volume, Internal Static Pressure and Installation Weight:**

Air volume, internal static pressure and installation weight are based on the air cleaner filter configuration. Refer to Table 3.

**Table 3. F116 (Series 16000) Filter Configuration, Recommended Air Volume, Internal Static Pressure and Hanging Weight with Filters.**

Model Numbers	Filter Configuration	Recommended Air Volume in cfm (m <sup>3</sup> /min)	Approximate Internal Static Pressure at Recommended Air Volume	Hanging Weight with Filters in lbs (kg)
F116A1021 (16002)	HEPA filter (99.997%)	1600 (49)	1.3" W.G.	149 (68)
F116A1047 (16004)	D.O.P. filter (95%)	1800 (52)	1.1" W.G.	130 (59)
	ASHRAE dust spot filter (95%)	2000 (58)	1.0" W.G.	108 (49)
	ASHRAE dust spot filter (65%)	2000 (58)	0.75" W.G.	108 (49)
	CPZ™ sorbent modules	1600 (49)	0.5" W.G.	143 (65)
F116A1120 (16012)	D.O.P. filter and CPZ™ sorbent modules	1600 (49)	1.3" W.G.	198 (90)
	ASHRAE dust spot filter (95%) with CPZ™ sorbent modules	1600 (49)	1.0" W.G.	175 (79)
	ASHRAE dust spot filter (65%) with CPZ™ sorbent modules	1600 (49)	0.8" W.G.	175 (79)
	Two sets of CPZ™ sorbent modules	1600 (49)	0.8" W.G.	211 (96)
	ASHRAE dust spot filter (65%) with D.O.P. filter	1800 (52)	1.5" W.G.	162 (74)
	Two ASHRAE dust spot filters (65%)	2000 (58)	1.6" W.G.	139 (63)
	ASHRAE dust spot filter (95%) with D.O.P. filter	Not recommended		

(continued)

**Table 3. F116 (Series 16000) Filter Configuration, Recommended Air Volume, Internal Static Pressure and Hanging Weight with Filters (continued).**

Model Numbers	Filter Configuration	Recommended Air Volume in cfm (m <sup>3</sup> /min)	Approximate Internal Static Pressure at Recommended Air Volume	Hanging Weight with Filters in lbs (kg)
F116E1001 (16000)	Electrostatic precipitator collecting cells	2000 to 2500 (58 to 72))	0.3" W.G. to 0.5" W.G.	164 (74)
F116E1100 (16010)	Electrostatic precipitator collecting cells with D.O.P. filter	1800 (52)	1.2" W.G.	220 (100)
	Electrostatic precipitator collecting cells with ASHRAE dust spot filter (95%)	2000 (58)	1.3" W.G.	198 (90)
	Electrostatic precipitator collecting cells with ASHRAE dust spot filter (65%)	2000 (58)	1.0" W.G.	198 (90)
	Electrostatic precipitator collecting cells with CPZ™ sorbent modules	1600 (49)	0.6" W.G.	233 (106)

**Table 4. F116 (Series 16000) Filter Description.**

Filter	Dimensions in in. (mm)	Efficiency	Comments
Prefilter	24 x 24 x 4 (610 x 610 x 102)	30% to 40%	Disposable pleated synthetic fiber in beverage board frame
HEPA	24 x 24 x 12 (610 x 610 x 305)	99.97% at 0.3 micron at 1600 cfm (49 m <sup>3</sup> /min)	D.O.P. in metal frame with aluminum pleat separators in the media
D.O.P.	24 x 24 x 12 (610 x 610 x 305)	95% at 0.3 micron at 1800 cfm (52 m <sup>3</sup> /min)	D.O.P. in metal frame
Electrostatic precipitator collecting cell	24 x 24 x 12 (610 x 610 x 305)	95% ASHRAE dust spot at 2500 cfm (72 m <sup>3</sup> /min)	Combination of ionizing wires, collecting plates and cell frame. Use for collection of nonconductive particulates. Must use two cells.
ASHRAE dust spot	24 x 24 x 12 (610 x 610 x 305)	95% ASHRAE dust spot at 2000 cfm (58 m <sup>3</sup> /min)	In metal frame
	24 x 24 x 12 (610 x 610 x 305)	65% ASHRAE dust spot at 2000 cfm (58 m <sup>3</sup> /min)	In metal frame
Sorbent Module— Contents: — charcoal only, — permanganate only, — zeolite only or — CPZ™ material (combination of the above ingredients)	11 1/2 x 11 1/2 x 23 (292 x 292 x 584)	85% first pass at 1600 cfm (49 m <sup>3</sup> /min) for most gases/odors	Ten panel disposable modules. Must use two modules.

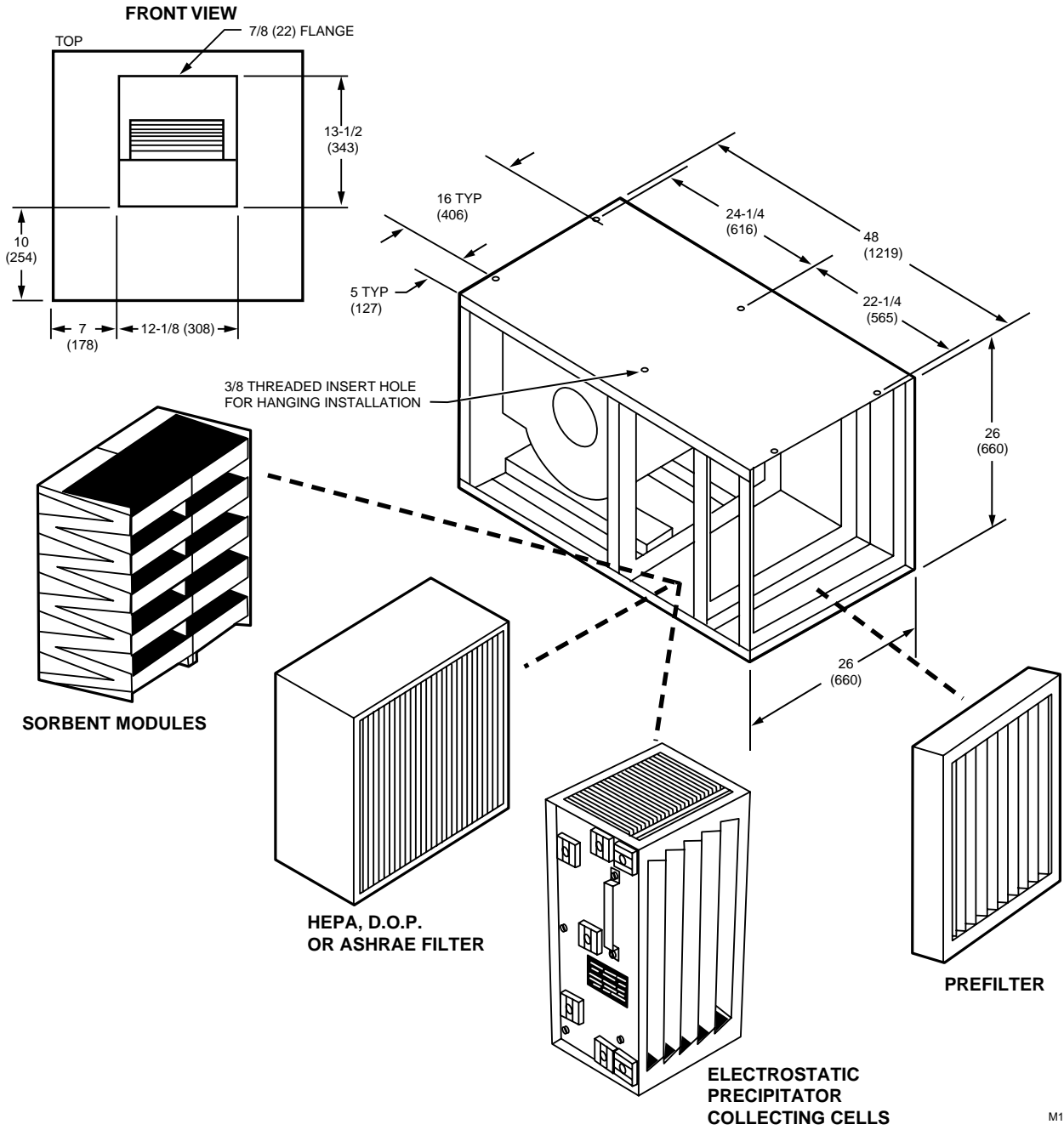


Fig. 1. Approximate dimensions of two stage filtering model in in. (mm).

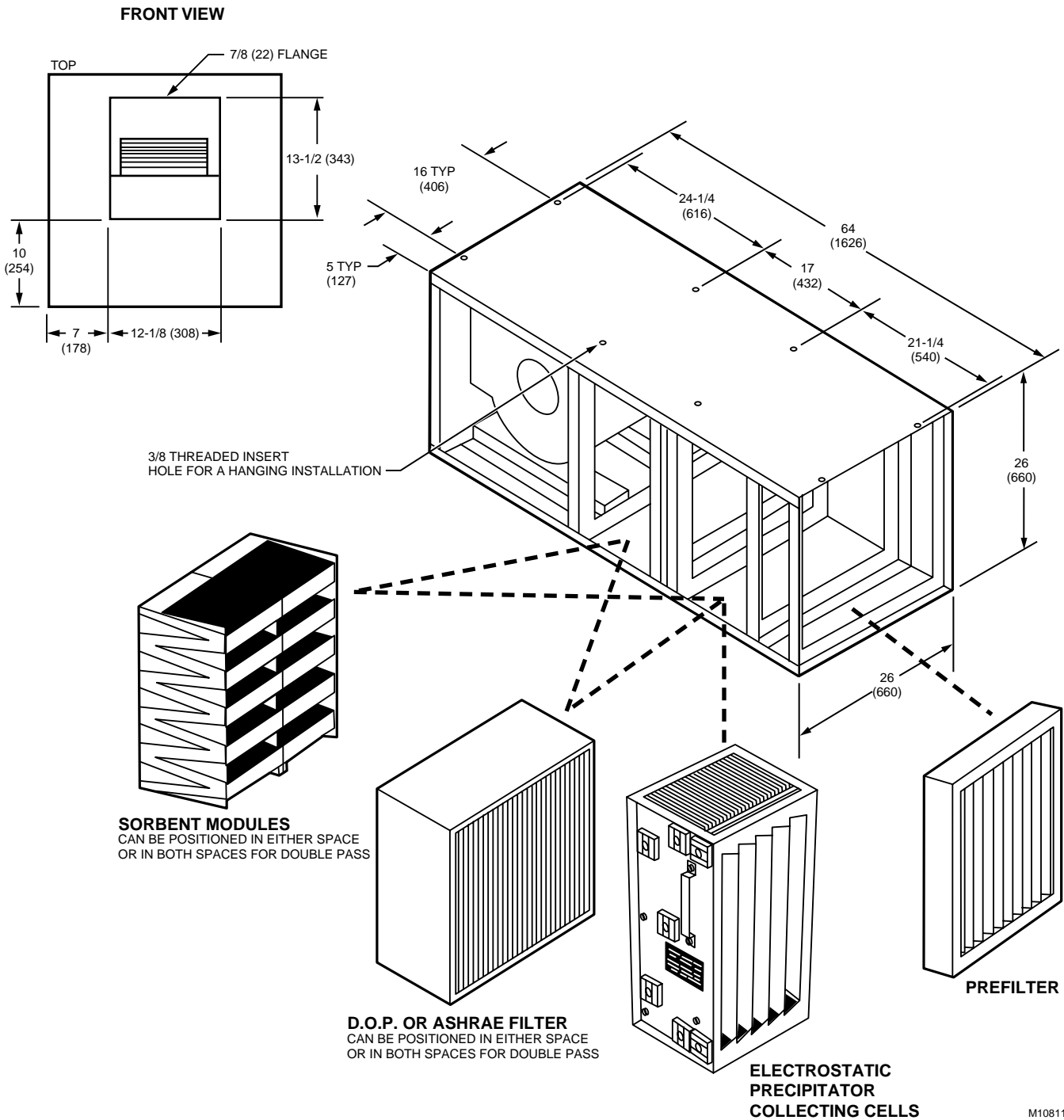


Fig. 2. Approximate dimensions of three stage filtering model in in. (mm).

## PLANNING THE INSTALLATION

### WARNING

**Explosion Hazard Possible**  
**Can cause personal injury or equipment damage.**

- Do not install or use where there is any danger of gas, vapor or dust explosion.
- Do not install when explosion proof electrical fixtures are specified.

## Application and Operation

The F116 (series 16000) self-contained ductable commercial air cleaner is designed for use in smoking areas, hospitals, in-plant office areas or plant satellite offices, printing shops, areas that do brazing, soldering or gluing and commercial cooking areas.

Because the air cleaner provides its own air circulation, it can be mounted in a duct system or independently. When used in a duct, the air cleaner air volume must be the same as the duct and plenum.

When the air cleaner is powered, the blower/motor draws the contaminated air into the air cleaner. Particles that are too small to be caught in the prefilter are trapped by the primary filter. When using the electrostatic precipitator collecting cells, the particles are given an electrical charge in the ionizer section of the cell. As the air passes through the collecting section of the cell, the charged particles adhere to the collector plates which have a strong electrical charge. The clean air is then discharged (two stage) or goes through a second primary filter (three stage) and is then discharged.

The air cleaner includes an ON and a cell performance indicator. The ON indicator lights when the solid state power supply is powered and operating normally. The cell performance indicator is on when the cells need to be cleaned.

## Static Pressure

The F116 (series 16000) uses a forward curve blower/motor. The electrical current draw is determined by combining the air volume to be moved with the filter and ducting static pressure.

### IMPORTANT

*Motor overload will occur if the combined filter and ducting static pressure is less than 1.2" W.G.*

The net air volume at 1.2" W.G. will vary from 2150 cfm (62 m<sup>3</sup>/min) on low speed to 2350 cfm (68 m<sup>3</sup>/min) on high speed. The maximum allowable electrical current draw for all speeds is between 13.5A and 14A at 120 Vac.

The blower turns off when a sufficient amount of air can not be drawn through the intake (1.85" W.G.) and the blower spins in a vacuum. A maximum blower pressure of 2.25" W.G. can occur which can have an air volume of 100 cfm (3 m<sup>3</sup>/min).

NOTE: No damage will occur to the air cleaner if operating at 1.85" W.G. pressure or higher.

The ideal system design has the ducting pressure combined with a clean filter pressure operating at 1.2" W.G. The motor should run at 14A at 120V. As the filters load, the resistance to airflow increases which causes the static pressure to increase while the electrical current draw and air volume decrease. The air volume loss is low for the first 0.5" W.G. of pressure increase from the initial 1.2" W.G.

EXAMPLE: At high speed the 1.2" W.G. air volume is approximately 2350 cfm (68 m<sup>3</sup>/min) and at 1.7" W.G. the air volume is approximately 2000 cfm (58 m<sup>3</sup>/min). But at 1.9" W.G. the air volume drops to approximately 1150 cfm (33 m<sup>3</sup>/min).

Loading does not resist airflow when using the electrostatic precipitator collecting cells and/or CPZ™ modules. However, a loaded prefilter does restrict the airflow. Refer to Fig. 3 and Table 3 for nominal air volume calculations and filter configuration pressures.

## INSTALLATION

### When Installing this Product...

1. Read these instructions carefully. Failure to follow them could damage the product or cause a hazardous condition.

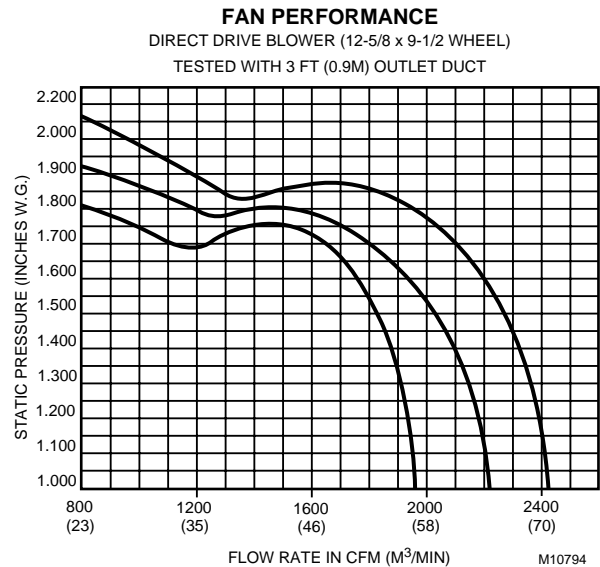


Fig. 3. Fan performance.

2. Check the ratings given in the instructions and on the product to make sure the product is suitable for your application.
3. Installer must be a trained, experienced service technician.
4. After installation is complete, check out product operation as provided in these instructions.



## CAUTION

- Do not connect the power source until after the air cleaner is mounted. This will prevent electrical shock or equipment damage.
- Be sure to turn off the air cleaner before servicing it.
- If the air cleaner must be turned on for an electrical check, be extremely careful to avoid electrical shock. Also, take care when working near the air cleaner moving parts.

## Choose Location and Mount

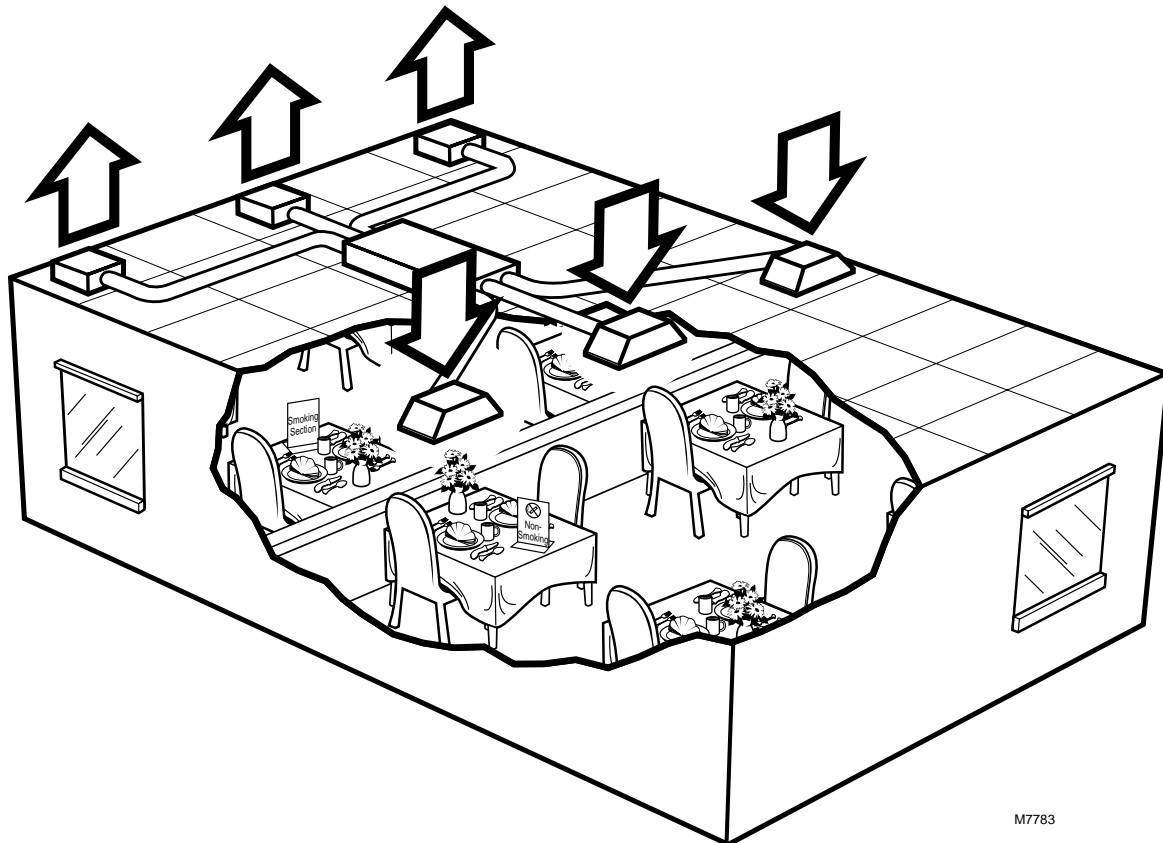
Choose a location that is readily accessible for regular inspection and cleaning. Allow enough room for removing the prefilter and primary filters. Be sure there is room for servicing without removing pipes, ducts or other heating system components. See Fig. 4 through 12 for suggested locations.

The air cleaner must be attached to a structure capable of supporting the weight of the unit with filters, ducting and plenums when used. Roof trusses, bar joists and floor joists are examples of suitable structures.

### IMPORTANT

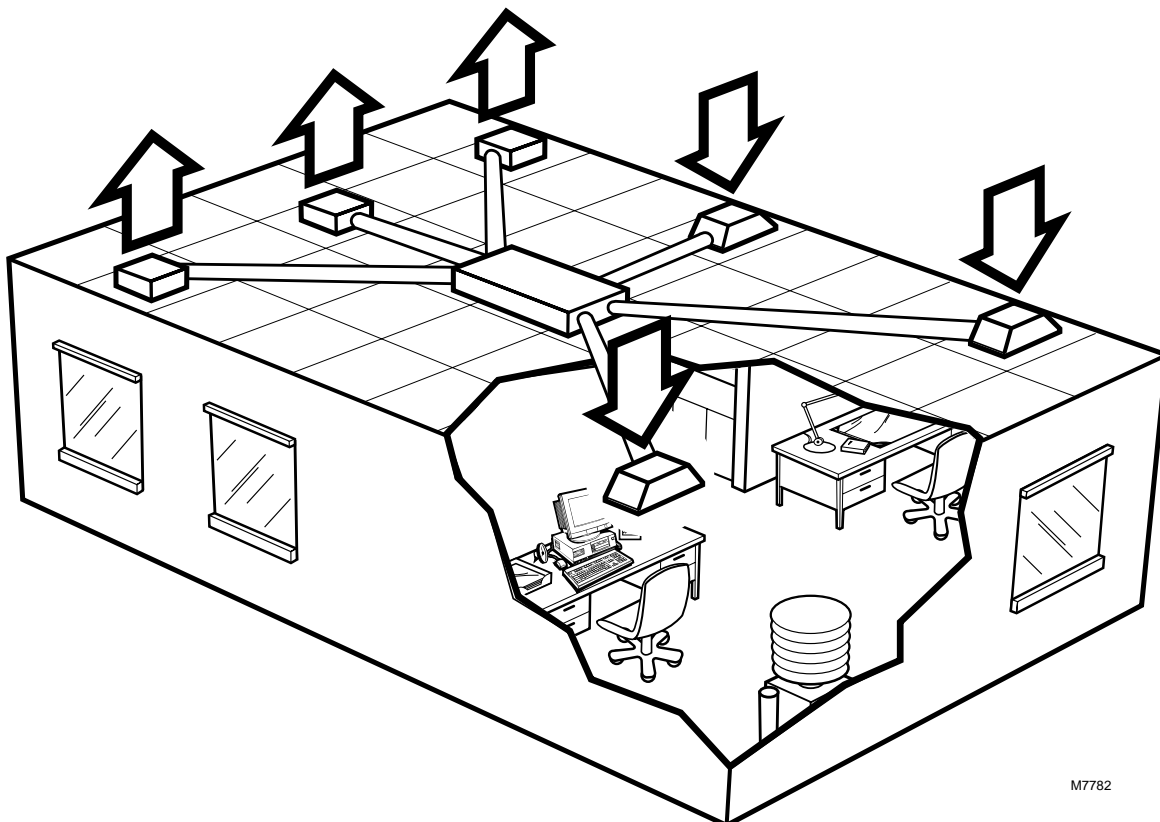
*All suspension points (either six or eight depending on the model) must be used for proper and safe installation. See Fig. 1 and 2 for dimensions between the suspension points.*

Threaded rod, eyebolts with chains, or any standard practice and hardware for hanging method can be used in the suspension of the air cleaner. See Fig. 13.



M7783

**Fig. 4. Positioning air cleaners at the far end of the restaurant smoking section to draw the smoke away from the nonsmoking section.**



M7782

**Fig. 5. Positioning air cleaners to create a negative pressure in polluted spaces and creating a positive pressure in nonpolluted areas. Use this positioning in in-plant offices and hospitals.**

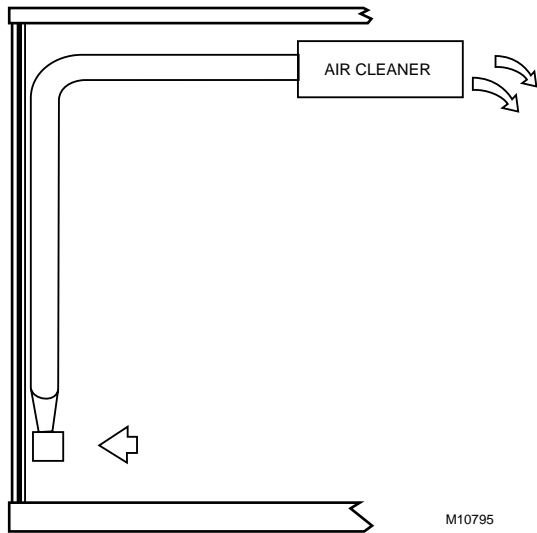


Fig. 6. Positioning air cleaner for printing shop, brazing, soldering or gluing vapor control.

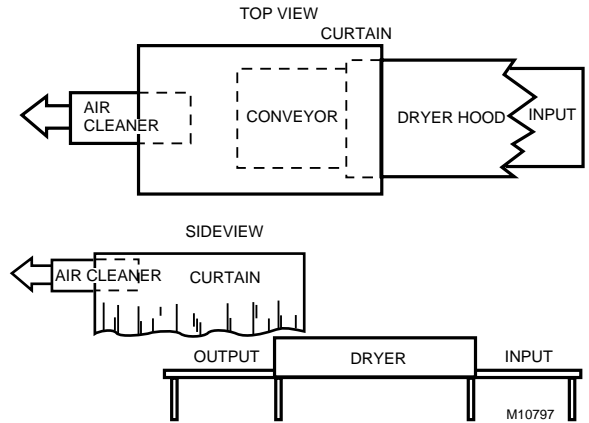


Fig. 8. Positioning air cleaner to remove pollutants from a conveyor feed process such as screen printing.

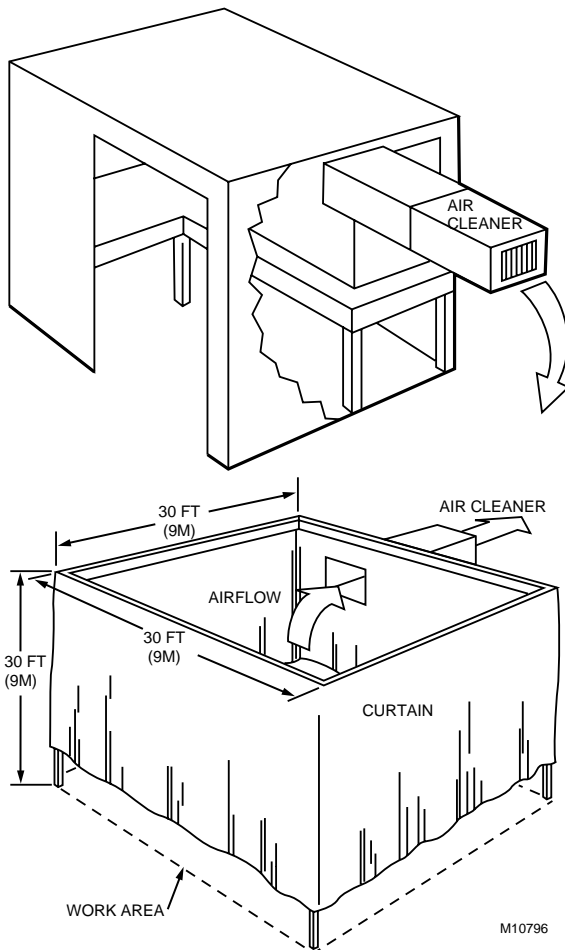


Fig. 7. Positioning air cleaner to create a negative pressure booth that contains a contamination generating process.

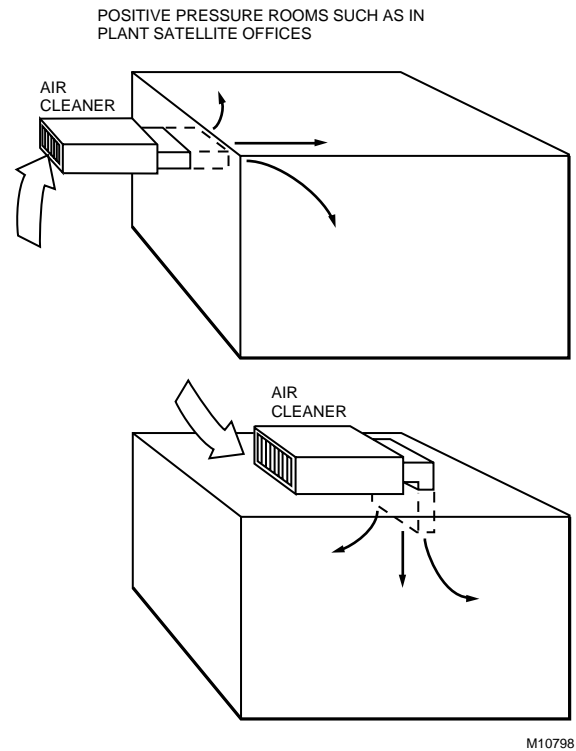
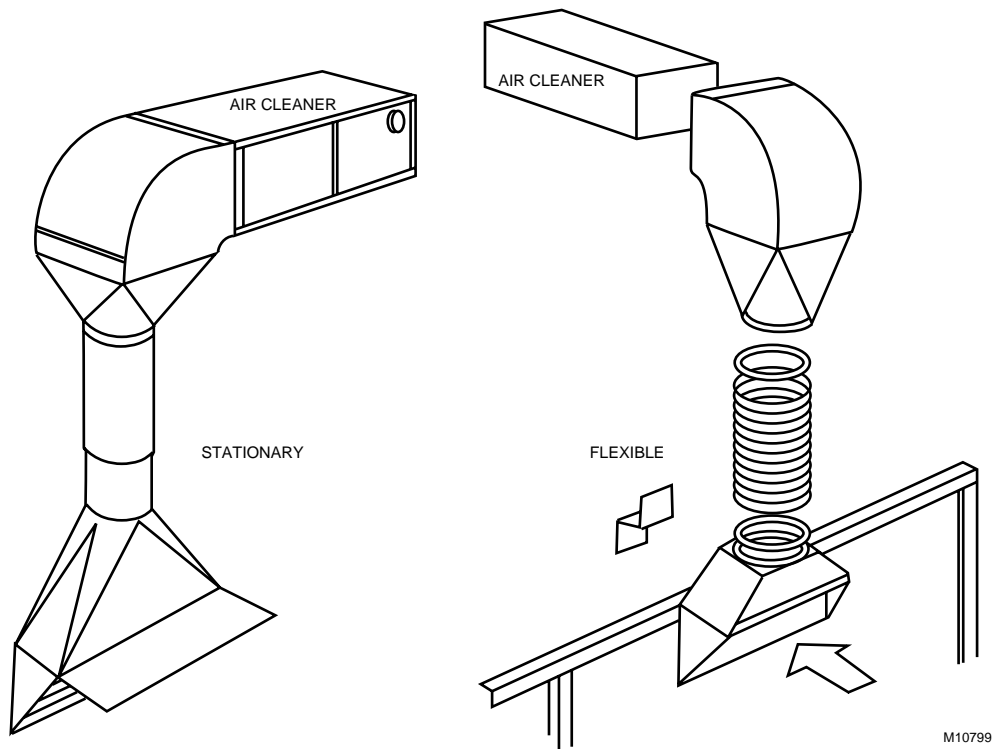
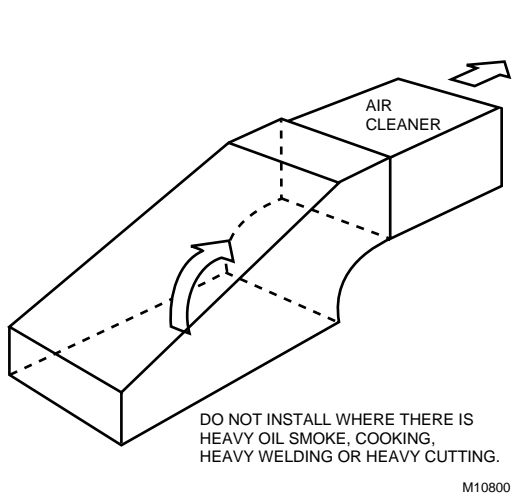


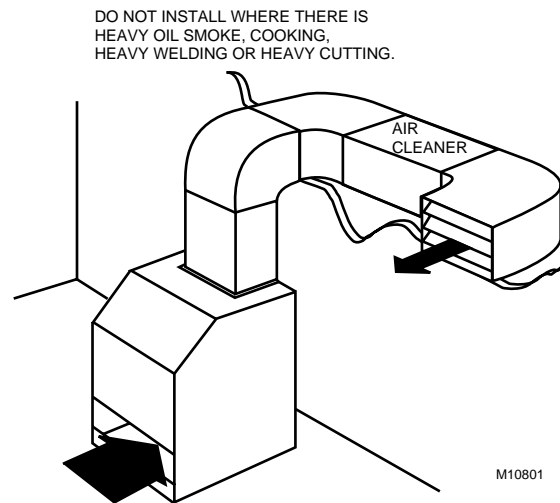
Fig. 9. Positioning air cleaner to create positive pressure for a plant satellite office.



**Fig. 10. Positioning air cleaner for suspended side draft applications.**

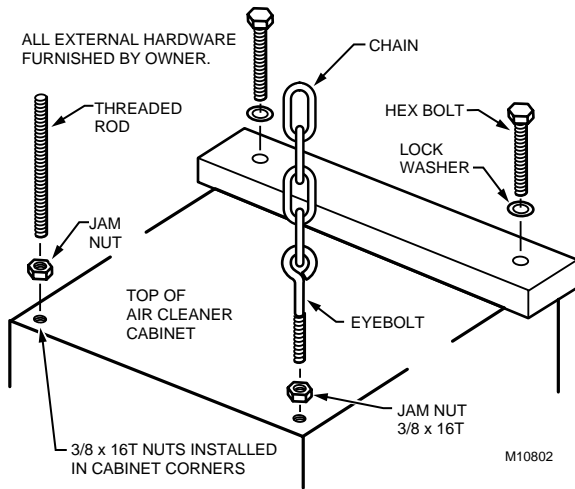


**Fig. 11. Connecting air cleaner directly to a canopy hood with a minimum air entrance velocity of 120 fpm.**



**Fig. 12. Positioning air cleaner to recirculate existing exhaust system air which contains light to medium quantities of pollutants.**

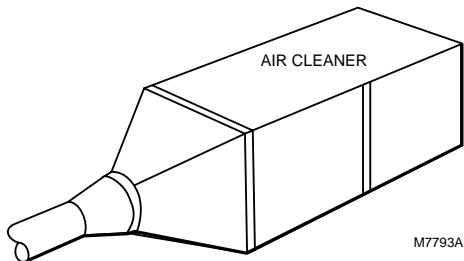
**FASTEN SECURELY TO STRUCTURAL SUPPORT SYSTEM  
I.E. BAR JOIST, CONCRETE SLAB, TIMBER FRAMING, ETC.**



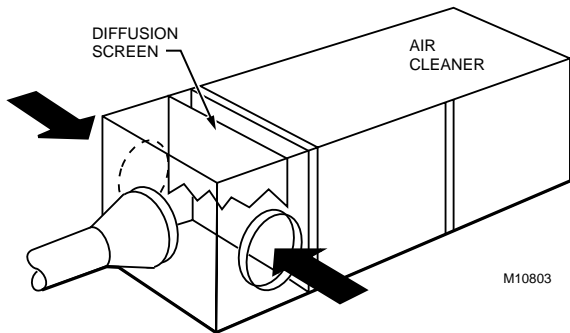
**Fig. 13. Fastening air cleaner to a structural support system (bar joist, concrete slab or timber framing).**

**Install with Ducting**

Use a transition or box plenum to attach the ducting to air cleaner inlet. A transition plenum is preferred. See Fig. 14. A diffusion screen must be installed when a box plenum is used. See Fig. 15. A box plenum can accommodate more than one inlet.

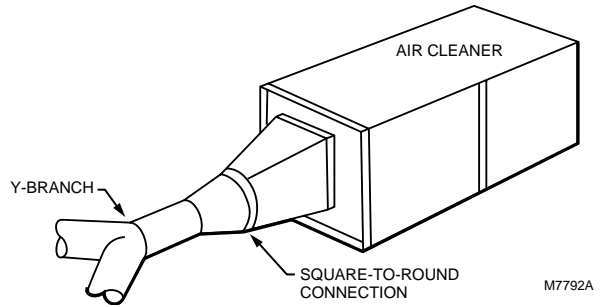


**Fig. 14. Transition plenum connected to the air cleaner inlet.**



**Fig. 15. Box plenum with diffusion screen and three inlets connected to the air cleaner.**

Use a square-to-round or square-to-square connection when attaching the air cleaner outlet to the blower discharge flange. See Fig. 16. The outlet connection can be used with a Y-branch, distribution box or manifold as required.



**Fig. 16. Square-to-round connection attached to the air cleaner outlet.**

**Wire**

All wiring must comply with applicable codes and ordinances. The power source must agree with the air cleaner electrical rating (120 Vac, 60 Hz).

1. Connect the power. See Fig. 17 and 18.

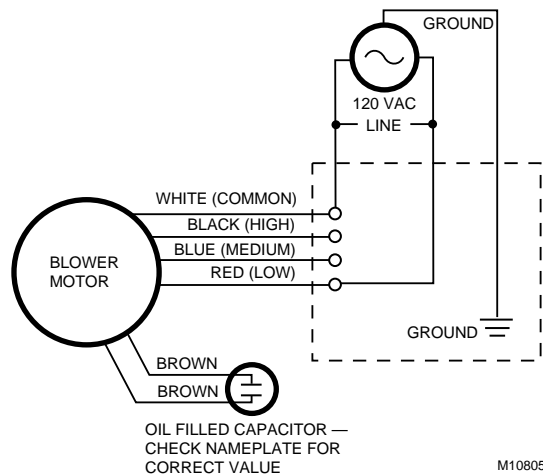
**IMPORTANT**

*Ground the air cleaner for proper operation and safety.*

2. Turn on the power and check that the blower operates at all three speed settings.
3. Check that the ON indicator lights when the fan is operating.
4. Turn off the power and install the filters in the cabinet.

**NOTE:** Select models have a disposable aluminum spacer. The spacer is necessary only when using the CPZ™ modules. All other filters need to remove and save the spacer for future needs.

5. Replace the air cleaner cover.



**Fig. 17. F116A1021, F116A1047 and F116A1120 series 16002, 16004 and 16012) air cleaner typical wiring diagram.**



## Cleaning the Electronic Cells (when used) Using Alkaline Base Detergent

### WARNING

**Sharp Edges.**

**Can cause personal injury.**

Handle the electronic cells (if used) carefully to avoid cuts from the sharp metal edges, collection plates and ionizer wires. Wear protective gloves.

**Steam, Hot Water, Strong Detergent.**

**Can Cause Personal Injury.**

- Wear rubber gloves, eye protection and rubber apron for protection.
- Keep detergent solution out of the reach of children.

1. Provide a large enough container, such as a laundry tub or plastic tank, to hold at least one cell.
2. Mix alkaline base detergent, such as commercial or home electric dishwashing detergent (either liquid or powder) with hot water. Follow the instructions on the detergent package. The water temperature should be between 150°F and 190°F (66°C and 88°C). When using a cold water detergent, follow instructions included with the detergent.

NOTE: Be sure to avoid prolonged skin contact with the solution. Do *not* splash solution in eyes.

3. Soak the cells in the solution for up to 15 minutes; agitate the cells up and down. See Fig. 19.

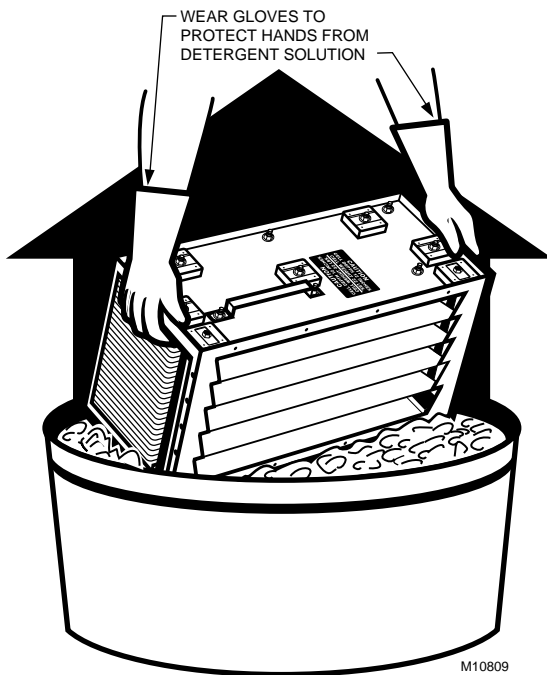


Fig. 19. Agitate the cells in the water.

4. Remove the cells from the detergent solution; spray with hot water as a prerinse, if desired and place cells in another container of clear hot water (150°F to 190°F [66°C to 88°C]) for final rinsing. Rinse the cells for five to ten minutes.
5. Remove the cells from the rinse water. Allow the cells to drain and dry before energizing them. For optimum water drainage from tubes, stand the cell on one of its corners.
6. Wipe ionizer wires to remove any deposits remaining on the wires.
7. Check the collection plates of the cells for any detergent residue. Repeat the rinse process if there is *any* residue remaining. Buildup can reduce the air cleaner efficiency.

### About Discolored Aluminum

Occasionally, the cells can seem stained after the soaking process. When the stain is black or very dark, it is probably dirt residue and the cell should be rewashed. White detergent residue can also affect the air cleaner efficiency and should be rinsed off. When yellowing appears, it is probably staining from tobacco smoke or other airborne dirt. Moderate discoloration does not affect the air cleaner efficiency.

### Cleaning the Cells Using Air Pressure, Water Pressure or Low Pressure Steam

The following alternative methods can be used to clean some contaminants from the electronic cells.

- **High Pressure Air or Water.** Care should be taken to avoid damage to the cells. If detergent is required with the high pressure water, use an alkaline base detergent. Do *not* use an acid detergent.
- **Steam.** Extreme care must be taken when steam cleaning to avoid warping or bending the collector plates of the cells. Remember that the cells are hot after steam cleaning and care must be taken to avoid burns. Use only low pressure or wet steam.

NOTE: Do not use steam at pressure greater than 5 psi (35 kPa) or temperature hotter than 250°F (121°C).

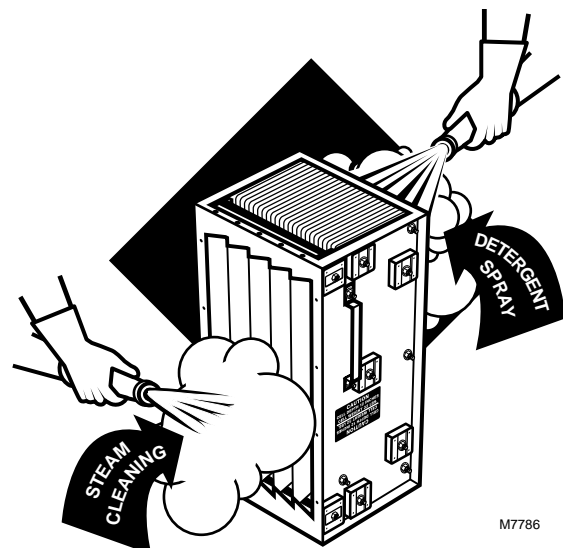


Fig. 20. High pressure water or steam cleaning the cells.

## Removing Specific Contaminants from Cells

Table 5 lists the appropriate cleaning procedure for types of contamination often found on cells. Cleaning procedures are listed in order of preference. Be careful to avoid bending the cell collector plates.

**Table 5. Recommended Cleaning Procedures for Specific Contaminants.**

Contaminant	Cleaning Procedure
Animal hair solution	Dishwasher detergent
Carbon (carbon black, soot, lamp black, graphite, charcoal dust)	Dishwasher detergent solution high pressure air or high pressure water
Cooking oils: Vegetable (soybean, peanut) or animal (lard, butter)	Dishwasher detergent solution or steam
Cotton fibers solution	Dishwasher detergent solution
Dust (silicon dioxide, calcium carbonate and mineral type compounds)	Dishwasher detergent solution
Flour dust	Dishwasher detergent solution
Mineral oil (petroleum base, diesters and silicone)	Dishwasher detergent solution or high pressure water
Paper products	Dishwasher detergent solution
Paint (oil base or water base)	Dishwasher detergent solution
Pine tar resins	Dishwasher detergent solution or steam
Soaps	Dishwasher detergent solution
Sodium chloride	Dishwasher detergent solution
Sugars (all types including molasses)	Dishwasher detergent solution or steam
Talc	High pressure air or Dishwasher detergent solution
Tobacco tars and smoke	Dishwasher detergent solution
Varnishes	Dishwasher detergent solution
Waxes (all types)	Dishwasher detergent solution or steam

## Reinstalling the Cells

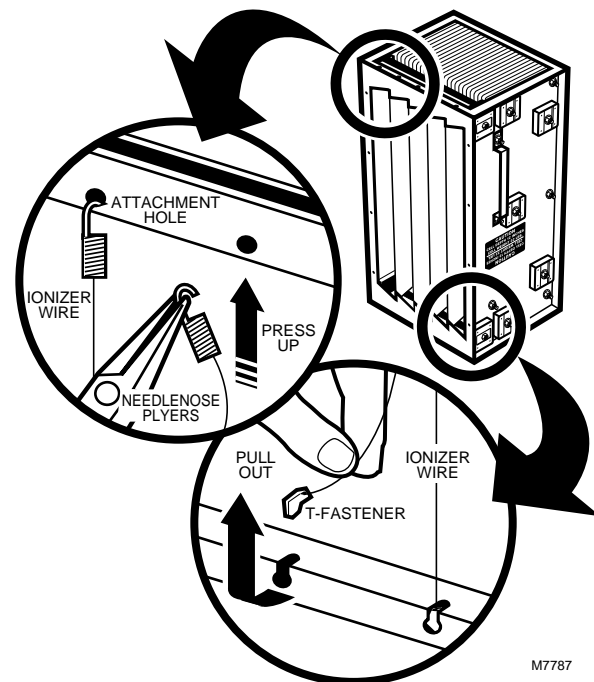
1. Inspect the cells for broken ionizer wires and bent collector plates. Bend warped or bent collector plates back into shape. For maximum efficiency, replace broken ionizer wires as instructed in Replacing Ionizer Wires section.
2. Wipe ionizer wires.

3. Check that cells are completely dry before reinstalling in the air cleaner. If cells are placed into the air cleaner while still wet, the electronic cells can short out and arc frequently when almost dry. Although the system appears to be operating, the cells may not be cleaning during the drying period.
4. Check that the ionizer wire side of the cell is the farthest from the fan.
5. Wipe surface dirt from the inside of the cabinet.
6. Ease the edge of the cell into the cabinet.
7. Replace the prefilter and any other primary filters.
8. Close and carefully latch the door.

## Replacing Ionizer Wires

Broken or bent ionizer wires can cause an electrical short to ground, often resulting in visible arcing or sparking. Remove broken wires. Cells can be used temporarily with one wire missing, but replace the wire as soon as possible. Replacement wires are cut to length with a T-fastener on one end and a spring on the other end for easy installation. To install:

1. Slip the ionizer wire T-fastener into a vacant wire key slot. See Fig. 21. Be careful to avoid damaging the ionizer wire or other parts of the cell.
2. Use a needlenose pliers to hold the opposite end of the wire and stretch the wire the length of the cell. Insert the spring loop into the wire hole.
3. Check the cell for short circuits using an ohmmeter. See Fig. 22. Check the resistance between the frame of the cell and both the ionizer and the collector contacts. In each case, the resistance should be infinite.



**Fig. 21. Install new ionizer wire by hooking spring loop end over wire hole edge.**

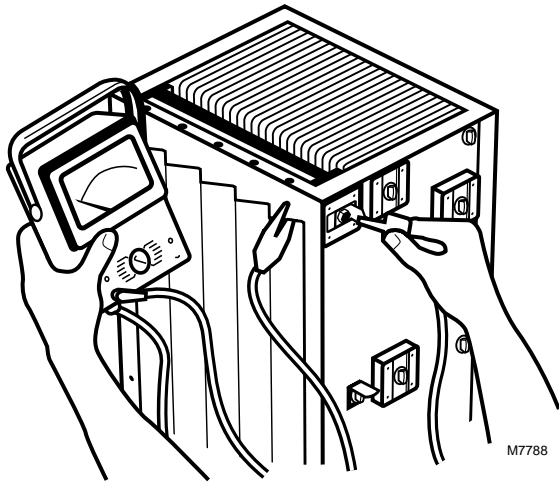


Fig. 22. Use an ohmmeter to check the cells for short circuits.

## TROUBLESHOOTING

### ⚠ WARNING

**Electrical Shock Hazard**

**Can cause personal injury or equipment damage.**  
The following procedures expose hazardous live parts. Disconnect power supply between checks and proceed carefully.

### ⚠ CAUTION

The following instructions are for use by only qualified personnel.

See Table 6 for troubleshooting procedures.

Table 6. Troubleshooting the F116 (Series 16000) Air Cleaner.

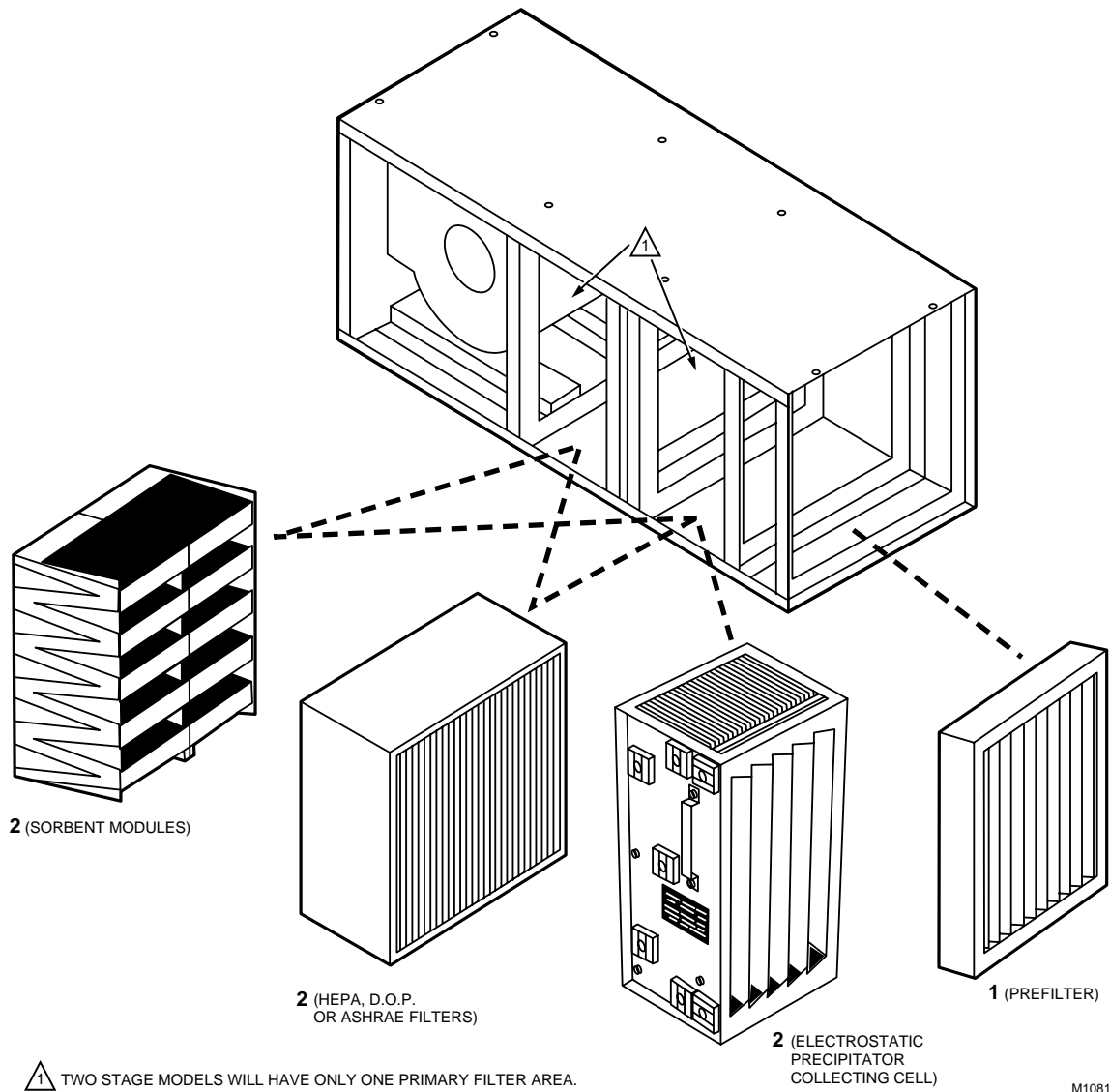
Symptom	What To Do
Motor will not start	<ul style="list-style-type: none"> <li>• Check wiring for loose connections—tighten</li> <li>• Check capacitor—replace if necessary</li> <li>• Check for hot motor—thermal protection relay is tripped, reset it</li> <li>• Replace motor</li> </ul>
Vibration — high frequency	Check that blower wheel is balanced—remove and balance or replace the wheel
Vibration — low frequency	Check if system is operating above 2.0" W.G. pressure—reduce total pressure by replacing filters
Scraping noise	Check if the blower wheel is touching the blower housing—adjust blower and position wheel in the center of the inlet ring
Squeal or whistle noise	Check for air leaks in the cabinet doors or ducting—plug air leaks
<b>ELECTROSTATIC PRECIPITATOR COLLECTOR CELL MODELS ONLY</b>	
No high voltage to cells	<ul style="list-style-type: none"> <li>• Check wiring for loose connections—tighten</li> <li>• Check for short in cells or configuration wires—fix</li> <li>• Check door interlock switch—fix</li> <li>• Check power supply pressure switch—fix</li> <li>• Check contact boards for ground—ground</li> <li>• Check for wet cells and ionizer wires—allow time for the cells and wires to dry</li> <li>• Replace power supply</li> </ul>
Excessive arcing and snapping	Check for: <ul style="list-style-type: none"> <li>• bent collecting plates</li> <li>• broken ionizer wires</li> <li>• debris lodged in cell frame collector plates</li> <li>• HV contact strips</li> <li>• HV wire shorting</li> </ul>

## PARTS LIST

Refer to Table 7 and Fig. 23 for the parts list and exploded view.

**Table 7. F116 (Series 16000) Self-Contained Ductable Commercial Air Cleaner Parts List.**

Fig. Reference No.	Description	Pack Qty	Order Number	Reference No.
1	Prefilter	1 Box of 6	32000200	860039
2	Primary Filters:			
	HEPA filter (99.97%)	1	32000198	860023
	D.O.P. filter (95%)	1	32000195	860024
	ASHRAE dust spot filter (95%)	1	32000196	860025
	ASHRAE dust spot filter (65%)	1	32000197	860026
	CPZ™ sorbent module (requires 2)	1	32000219	31005
	Charcoal only sorbent module (requires 2)	1	32000220	31006
	Zeolite only sorbent module (requires 2)	1	32000221	31007
	Permanganate only sorbent module (requires 2)	1	32000222	31008
Electrostatic precipitator collecting cell (requires 2)	1	32000199	860038	
Parts not shown				
3	Blower/motor	1	32000552	N/A
4	Capacitor, 120V	1	32000551	N/A



**Fig. 23. Exploded view of F116 (series 16000) self-contained ductable commercial air cleaner components.**

## WARRANTY

Honeywell Inc. warrants its air cleaner products to be free from defects in workmanship or materials under normal use and service, for a period of two (2) years from the date of purchase by the original end-user. If at anytime during the warranty period the product is defective or malfunctions, Honeywell Inc., through the distributor or dealer, from which the product was purchased, or through an authorized warranty repair station, shall at Honeywell's option, replace or repair the defective product or component.

This warranty does not cover removal or installation costs. This warranty shall not apply if it is shown that the defect or malfunction was caused by damage which occurred during handling or shipment, improper electrical connections, improper use of the product or abuse.

Honeywell Inc.'s sole responsibility shall be to repair or replace the product within the terms stated above. **HONEYWELL INC. SHALL NOT BE LIABLE FOR ANY LOSS OR DAMAGE OF ANY KIND, INCLUDING ANY INCIDENTAL OR CONSEQUENTIAL DAMAGES RESULTING, DIRECTLY OR INDIRECTLY, FROM ANY BREACH OF WARRANTY, EXPRESS OR IMPLIED, OR ANY OTHER FAILURE OF THIS PRODUCT.** (Some states do not allow the exclusion or limitation of incidental or consequential damages, so this limitation may not apply to you.) **THE WARRANTIES SET FORTH HEREIN ARE EXCLUSIVE AND HONEYWELL INC. EXPRESSLY DISCLAIMS ALL OTHER WARRANTIES, WHETHER WRITTEN OR ORAL, IMPLIED OR STATUTORY, INCLUDING BUT NOT LIMITED TO ANY WARRANTIES OF MERCHANTABILITY, WORKMANSHIP, OR FITNESS FOR A PARTICULAR USE.**

This warranty gives you specific legal rights and you may have other rights which vary from state to state.

### **How to make a warranty claim or have questions answered:**

Should you have a warranty claim or questions about the warranty policy, contact the distributor or dealer from which you purchased the product or the authorized warranty repair stations nearest your location.

NOTE: Do not return any products or parts to the factory without a factory issued "Returned Warranty Goods Label" issued by the Honeywell Inc. customer service department.

**In the event you or other persons, have any questions concerning the use and care of this product or this warranty please call or write the factory.**

**Honeywell Inc.  
Commercial Air Products  
1985 Douglas Drive N MN10-2525  
Golden Valley, MN 55422-3992  
Telephone: 612-954-6945, or 1-800-998-1919  
Fax: (800) 221-3248**



**Home and Building Control**

Honeywell Inc.  
Honeywell Plaza  
P.O. Box 524  
Minneapolis MN 55408-0524

**Honeywell Latin American Region**

480 Sawgrass Corporate Parkway  
Suite 200  
Sunrise FL 33325

**Home and Building Control**

Honeywell Limited-Honeywell Limitée  
155 Gordon Baker Road  
North York, Ontario  
M2H 3N7

**Honeywell Europe S.A.**

3 Avenue du Bourget  
1140 Brussels  
Belgium

**Honeywell Asia Pacific Inc.**

Room 3213-3225  
Sun Hung Kai Centre  
No. 30 Harbour Road  
Wanchai  
Hong Kong

---

**Honeywell**

