

F57A,B Flush-Mount Commercial Electronic Air Cleaner

SPECIFICATION DATA



FEATURES

- Removes staining dirt from the air as measured by the Dust Spot Method using atmospheric dust; refer to the American Society of Heating, Refrigerating, and Air Conditioning Engineers Standard 52.1-92.
- Three-speed motor-driven fan circulates up to 1030 cfm (1750 cu m/hr) on F57A, up to 485 cfm (714 cu m/hr) on F57B.
- Solid state power supply is self-regulating and maintains peak efficiency during a wide range of cell dirt-loading conditions.
- Interlock switch prevents operation when the grille is open.
- Heavy duty commercial cells and prefilter are removable for cleaning.
- Air vent provides dilution of gaseous contaminants.
- Provides Coanda air distribution by drawing in dirty air, cleaning it electronically, and recirculating the clean air in four directions throughout the space.
- Test button shows the presence of high voltage.
- Light emitting diodes (LED) indicate ON and CHECK; the WASH LED is optional.

APPLICATION

The F57A,B Flush-Mount Commercial Electronic Air Cleaners are ceiling-mounted. The F57 removes airborne contaminants such as tobacco smoke and dust from the air circulated through the unit.

SPECIFICATIONS

Models:

F57A Flush-Mount Commercial Electronic Air Cleaner: Contains two FC37B heavy duty commercial cells, power supply assembly, prefilter, inlet-outlet grille, power and speed control switch, performance selection switch, collector test button, three-speed motor-driven fan, interlock switch for the access grille, vinyl trim flanges, exhaust air vent and LED indication of system operation.

F57B Flush-Mount Commercial Electronic Air Cleaner: Contains one FC37B heavy duty commercial cell, power supply assembly, prefilter, inlet-outlet grille, power and speed control switch, performance selection switch, collector test button, three-speed motor-driven fan, interlock switch for the access grille, vinyl trim flanges, exhaust air vent and LED indication of system operation.

Color:

Off-white.

Electrical Ratings:

Voltage and Frequency: 120 Vac, 60 Hz or 220/240 Vac, 50/60 Hz, specify when ordering.



F57A,B FLUSH-MOUNT COMMERCIAL ELECTRONIC AIR CLEANER

Current and Power Consumption:

Model	Fan Setting	120 Vac, 60 Hz		220/240 Vac, 50/60 Hz	
		Current (A)	Power Consumption (W)	Current (A)	Power Consumption (W)
F57A	HI	3.9	315	1.8	315
	MED	3.2	300	1.4	250
	LOW	2.4	200	1.2	205
F57B	HI	4.3	255	1.9	275
	MED	2.1	185	1.0	150
	LOW	1.2	85	0.7	100

Motor:

F57A: 1/12 hp; sealed ball bearing.
 F57B: 1/10 hp; sealed ball bearing.
 Motor lubrication is not required.

Temperature Ratings:

Operating: This equipment is intended for use at ambient temperatures that are usually not higher than 77°F (25°C) but occasionally may be as high as 104°F (40°C) for brief periods.
 Storage and Shipping Ambient: -20°F to +150°F (-29°C to +66°C).

Dimensions:

See Fig. 1 and 2.

Airflow Capacity:

Model	Fan Setting	120 Vac, 60 Hz		220/240 Vac, 50/60 Hz	
		cfm	cu m/hr	cfm	cu m/hr
F57A	HI	1030	29	875	25
	MED	690	20	730	21
	LOW	555	16	640	18
F57B	HI	485	14	460	13
	MED	280	8	375	11
	LOW	175	5	260	7

Weight:

	F57A		F57B	
	lb	kg	lb	kg
Heavy duty commercial cell (each)	9.5	4.3	9.5	4.3
Shipping weight	106.0	48.1	64.0	29.0
Installed weight	83.0	37.6	54.0	24.5

Approvals:

Underwriters Laboratories Inc. Listed: File no. E30954,
 Guide no. AGGZ.
 Canadian Standards Association Certified: File no. LR19060.

Home and Building Control

Honeywell Inc.
 Honeywell Plaza
 P.O. Box 524
 Minneapolis MN 55408-0524

Home and Building Control

Honeywell Limited-Honeywell Limitée
 155 Gordon Baker Road
 North York, Ontario
 M2H 3N7

Honeywell Asia Pacific Inc.

Room 3213-3225
 Sun Hung Kai Centre
 No. 30 Harbour Road
 Wanchai
 Hong Kong

Honeywell Latin American Region

480 Sawgrass Corporate Parkway
 Suite 200
 Sunrise FL 33325

Honeywell Europe S.A.

3 Avenue du Bourget
 1140 Brussels
 Belgium

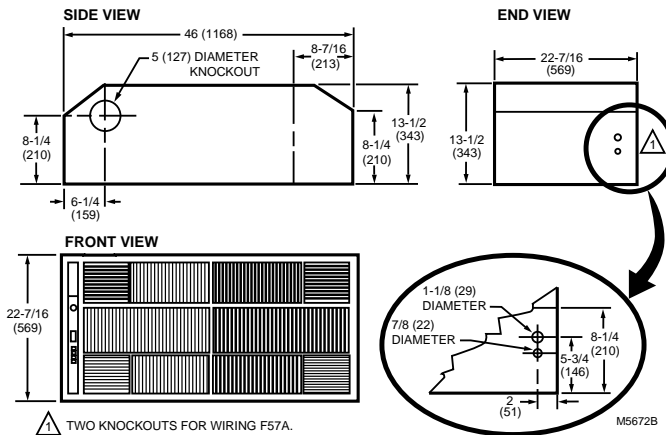

Fig. 1. Approximate dimensions of F57A in. in. (mm).

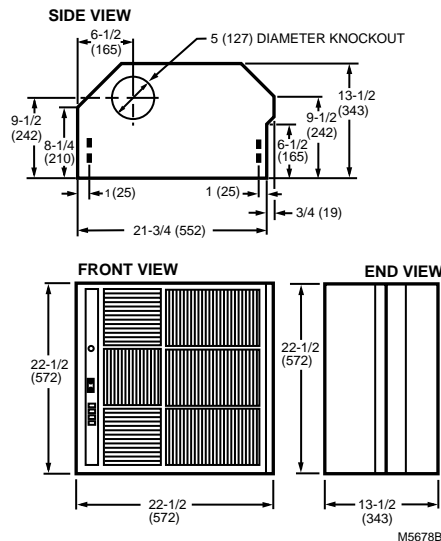

Fig. 2. Approximate dimensions of F57B in. in. (mm).

