

F58F Commercial Duct Mounted Electronic Air Cleaner

PRODUCT DATA



APPLICATION

The high efficiency F58F Commercial Electronic Air Cleaner is mounted in the return air duct of a forced-air heating, cooling, or ventilating system. It captures a significant amount of airborne particles 0.5 microns and larger from the air circulated through it.

FEATURES

- Adapts to airflow from either side.
- Capacity to 2000 cfm (3400 m3/hr).
- Solid-state power supply is self-regulating and maintains peak efficiency during a wide range of cell dirt loading conditions.
- Pressure drop is approximately equal to that of a regular fiberglass filter.
- Optional W8600F Air Cleaner Monitor indicates air cleaner performance, reminds owner when a cell and prefilter wash is due, and when to check the system.
- Electronic cells can be washed in most dishwashers.
- Galvanized cabinet protects against rust.
- Neon light next to the on-off switch indicates if the air cleaner is powered and if high voltage is present.
- Test button checks system operation.
- Troubleshooting guide mounted inside the cell access door.
- Permanent wash reminder schedule included for mounting in a convenient location.
- Prefilter screens protect cells from large dirt particles.

Contents

Application	1
Features	1
Specifications	2
Ordering Information	2
Planning the Installation	4
Installation	6
Operation	12
Checkout	12
Electrical Troubleshooting	16
Replacement Parts/Exploded View	18



SPECIFICATIONS

IMPORTANT

The specifications given in this publication do not include normal manufacturing tolerances. Therefore, this unit may not exactly match the listed specifications. This product is tested and calibrated under closely controlled conditions, and some minor differences in performance can be expected if those conditions are changed.

Model:

F58F Commercial Electronic Air Cleaner: Includes cabinet, access door, solid state power supply, two electronic cells and two prefilters.

Electrical Ratings:

Voltage and Frequency: 120V, 60 Hz. Two-cell 120V, 60 Hz models can be converted in the field to 240V, 60 Hz or 220/240V, 50 Hz with the 203365A kit.

Power Consumption: 36W maximum

Current Draw: 0.4A at 120V, 60 Hz and 0.2A at 240V, 60 Hz or 220/240V, 50 Hz.

Ionizer Voltage: 8150 Vdc.

Collector Voltage: 4075 Vdc.

Capacity, Efficiency, Pressure Drop:

See Fig. 1.

Temperature Ratings:

Operating Ambient: 40°F to 125°F (4°C to 52°C).

Temperature of Airflow Through Cells: 40°F to 125°F (4°C to 52°C).

Maximum Cell Washing Temperature: 220°F (140°C).

Storage and Shipping Ambient: Minus 40°F to plus 140°F (minus 40°C to plus 60°C).

Mounting:

Mounts in the return air duct of a forced air heating, cooling, or ventilating system. Should be mounted upstream from the atomizing humidifier. See Planning the Installation section.

Weight:

Electronic Cell (each): 9 3/16 lb (4.2 kg).

Shipping Weight: 42 lb (19.1 kg).

Installed Weight (cells included): 37 lb (16.8 kg).

Dimensions:

See Fig. 2.

Approvals:

Underwriters Laboratories Inc. Listed: File No. E30954.

Canadian Standards Association Certified: File No. LR95329-1.

Accessories:

203365A Conversion Kit for changing 120V, 60 Hz power supply to 240V, 60 Hz or 220/240, 50 Hz.

W8600F Air Cleaner Monitor.

Repair Parts:

See Replacement Parts/Exploded View section.

ORDERING INFORMATION

When purchasing replacement and modernization products from your TRADELINE® wholesaler or distributor, refer to the TRADELINE® Catalog or price sheets for complete ordering number.

If you have additional questions, need further information, or would like to comment on our products or services, please write or phone:

1. Your local Home and Building Control Sales Office (check white pages of your phone directory).
2. Home and Building Control Customer Logistics
Honeywell Inc., 1885 Douglas Drive North
Minneapolis, Minnesota 55422-4386 (612) 951-1000

In Canada—Honeywell Limited/Honeywell Limitée, 155 Gordon Baker Road, North York, Ontario M2H 3N7.

International Sales and Service Offices in all principal cities of the world. Manufacturing in Australia, Canada, Finland, France, Germany, Japan, Mexico, Netherlands, Spain, Taiwan, United Kingdom, U.S.A.

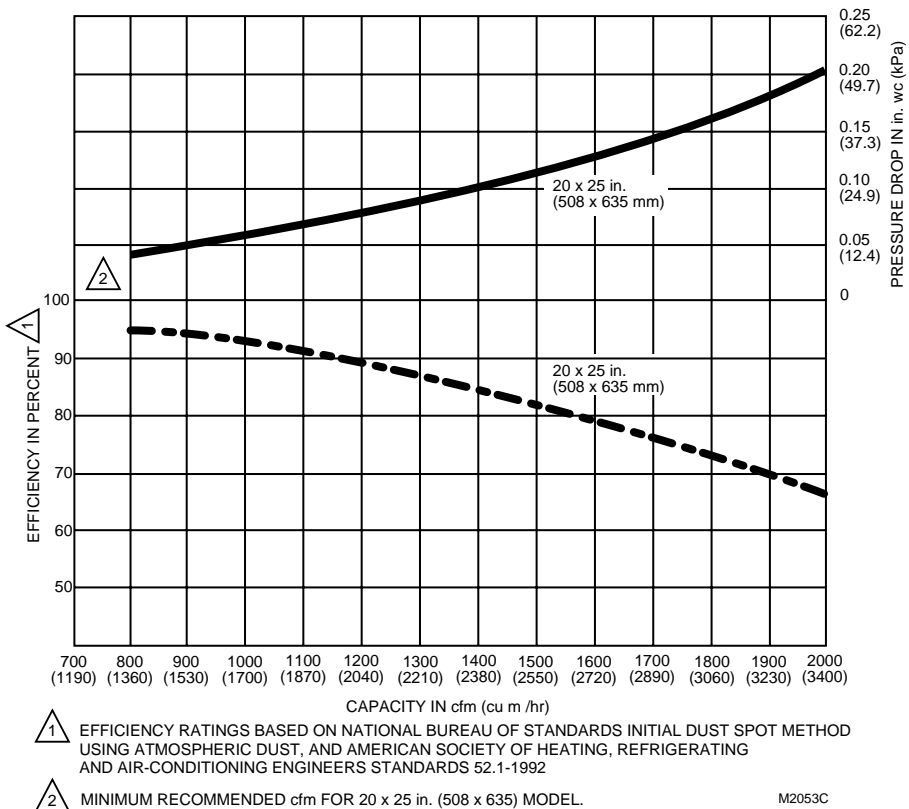

Fig. 1. Air cleaner efficiency and pressure drop at various airflow rates.

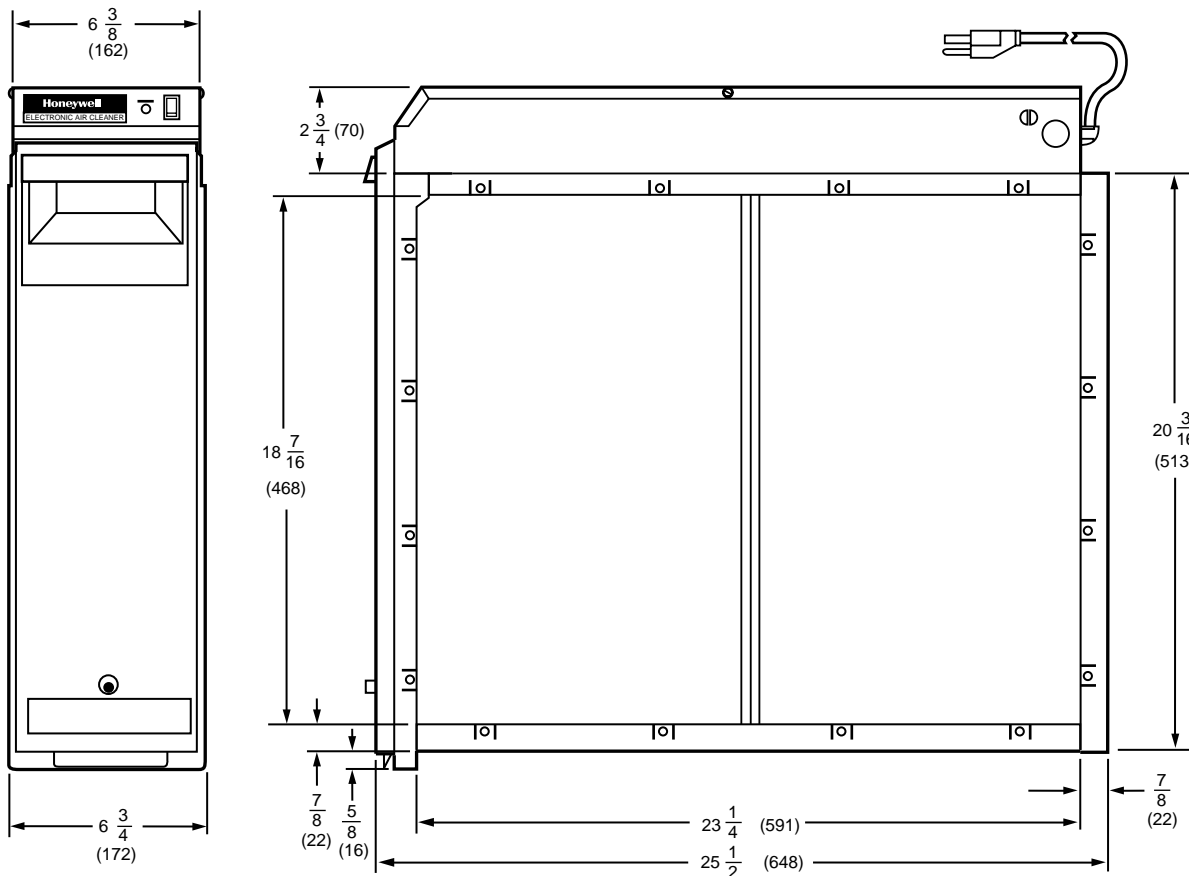

Fig. 2. Installation dimensions of Electronic Air Cleaner in in. (mm).

M5994

PLANNING THE INSTALLATION

Application

The F58F is used in a forced air heating, cooling, or ventilating system. It removes airborne particles from the air circulated through it. All models have an internal airflow switch to operate the F58F when the system blower is on.

Review Installation Requirements

The air cleaner should be installed where all the air passing through the system circulates through it. The best location is in the return air duct next to the blower compartment so the air cleaner can help keep the blower motor and evaporator coils clean.

IMPORTANT

Do not mount in the discharge air duct.

For most efficient air cleaning, airflow must be spread evenly across the face of the air cleaner. If the duct is a different size than the air cleaner cabinet, gradual transitions are recommended. If the duct turns sharply just before the air cleaner, turning vanes are recommended.

Applications with Air Conditioning

The air cleaner should be installed upstream from the evaporator coil. The air cleaner will help keep the coil clean, reducing maintenance.

Applications with a Humidifier

An evaporative humidifier can be mounted upstream from the air cleaner. An atomizing humidifier should be mounted downstream from the air cleaner, even though hard water salts will be blown into the living space and deposited as dust. If an atomizing humidifier must be mounted upstream from the air cleaner:

1. Mount it as far as possible upstream from the air cleaner.
2. Install a standard disposable furnace filter between the humidifier and the air cleaner to trap water droplets and hard water salts.
3. Frequently clean the air cleaner to prevent a hard water salt buildup.

NOTE: The volume of water that passes through an atomizing humidifier can overload the air cleaner, resulting in hard water salts being deposited as dust in the living space.

Applications with an Activated Carbon Filter

An activated carbon (charcoal) filter can be used to remove odors or other gaseous contaminants (not particle-based) that are not removed by the air cleaner. Locate the carbon filter:

- Downstream from the air cleaner. This means that dust from the carbon filter will not be collected by the air cleaner and will be deposited in the living space.
- Outside the air cleaner cabinet. Some carbon filters are combustible and contact with high voltage could result in smoke or fire.

- Where carbon granules cannot fall into the electronic cell. If necessary, use a disposable furnace filter between the carbon filter and the electronic cell.
- With proper transitions, if the activated carbon filter requires a differently sized duct than the air cleaner. Allow 20 degrees expansion per side, per fitting.

NOTE: Honeywell does not offer carbon filters. Refer to an activated carbon filter manufacturer for sizing and application.

Applications with Outdoor Air Intake

Return air temperature must be at least 40°F (4°C). Lower temperatures can cause ionizer wire failure. If outdoor air is used, warm it upstream from the air cleaner by:

- Making sure the outdoor intake is far enough upstream from the air cleaner so the return and outdoor air is thoroughly mixed. Stratified air can dump a stream of very cold air into one section of the air cleaner.
- Adding baffles upstream from the air cleaner to force thorough air mixing.
- Installing a Honeywell Home Ventilation System that transfers up to 80 percent of the heat from the exhaust air to the incoming outside air. This keeps the incoming air above 40°F (4°C) and reduces energy usage.
- Installing a preheater if large amounts of outdoor air are used. The preheater, which could be an electric strip heater or hot water coil, should be controlled by a thermostat. Hot water or steam coils should be protected by a freeze-up control.

Optional W8600F Air Cleaner Monitor

The F58F terminal board is recessed slightly so it or the wires will not interfere with installation. The entire power supply box can be unplugged and removed to provide access to the terminals. The W8600F Air Cleaner Monitor can be mounted in the living area or in the furnace room. It should be located in a convenient location to observe the display.

Choose F58F Location

Choose a location that is readily accessible for regular inspection and cleaning. Allow at least 13 in. (330 mm) in front of the access door for removing the prefilter and electronic cell. Allow enough room above the power supply so it can be serviced without removing pipes, ducts, or other heating system components.

The air cleaner must be installed where the temperature will not exceed 40° to 125°F (4° to 52°C).

Choose Mounting Position

WARNING

Heavy Equipment.

Can cause injury or equipment damage.

Do not mount the air cleaner with the access door facing down. If the access door faces down, the latch may not hold, and the cell and prefilter can fall unexpectedly. Also, nothing holds the cell and prefilter in place when the access door is opened.

The air cleaner can be mounted in any position except with the access door facing down.

Multiple electronic air cleaner installations are needed for many commercial systems. Air cleaners can be mounted back-to-back.

Carefully plan the number of air cleaners and positions before beginning installation. To visualize the plan of installation, temporarily arrange the desired number of air cleaners on the floor. Consider the air cleaners total dimensions, clearance and accessibility before selecting a location.

Back-to-Back Mounting

When mounting two cabinets back-to-back, allow at least 13 in. (330 mm) on each side (total of 26 in. [660 mm]) to remove cells and protective screens for cleaning. See Fig. 3.

Allow 1/4 to 3/8 in. (6.4 to 9.6 mm) between adjoining back ends of the cabinet for protruding tray tabs. Tray tabs extend 1/8 in. (3.2 mm) and must not be bent.

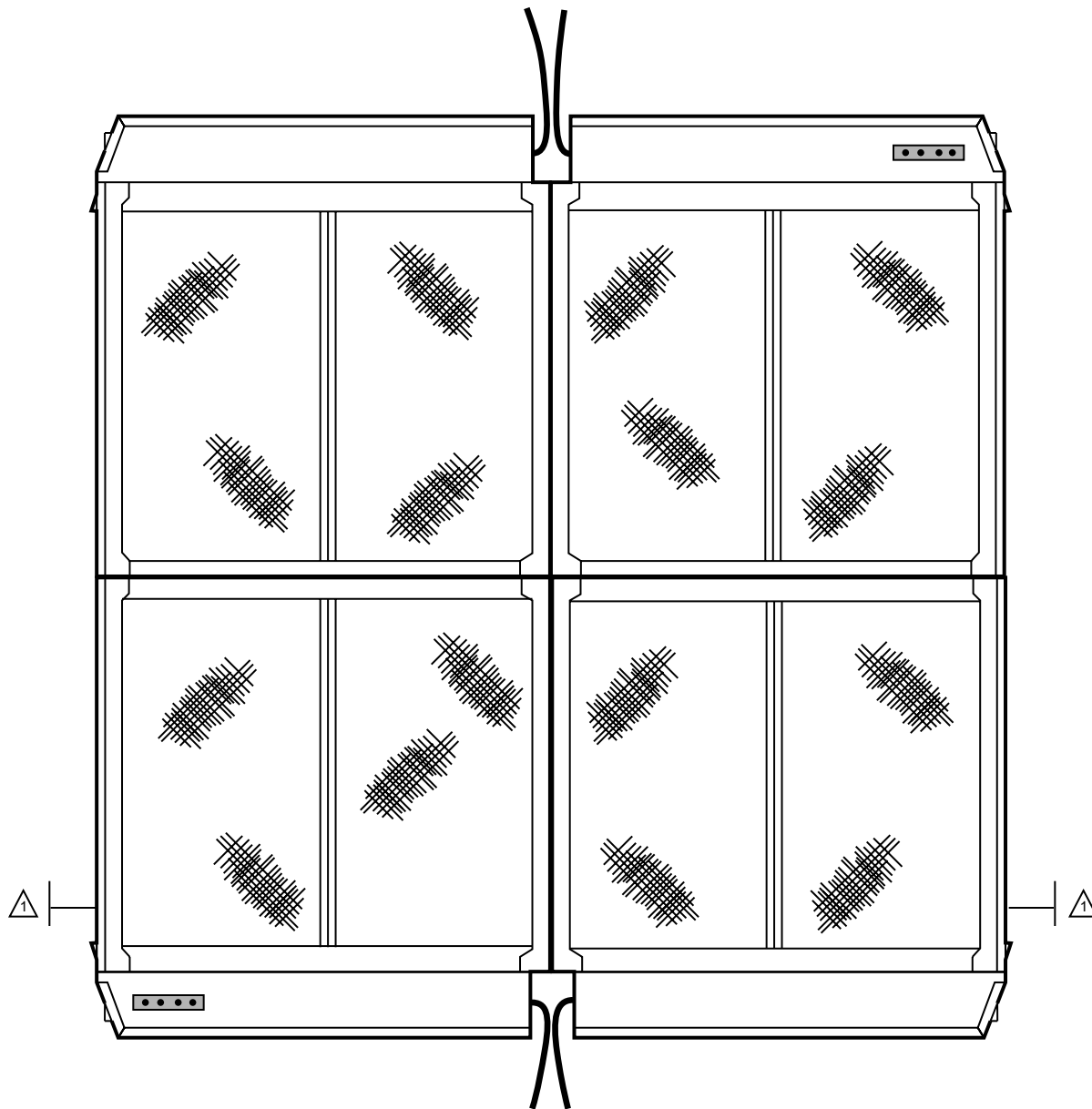

 ALLOW 13 IN. [330 MM] MINIMUM FOR CELL AND SCREEN REMOVAL.

M5769

Fig. 3. Typical multiple installation of F58F Electronic Air Cleaners.

Determine Duct Design Requirements

The air cleaner is adaptable to all new or existing forced air heating, cooling and ventilating systems used in residential applications. Transitions, turning vanes, or offsets may be needed in some applications for effective operation.

Transitions

Transitions are needed when the duct is a different size than the air cleaner cabinet. Gradual transitions reduce air turbulence and increase efficiency. Limit expansion to no more than 20 degrees or about 4 in. per running foot (100 mm per 300 linear mm) on each side of a transition fitting. See Fig. 4.

CHANGE DUCT SIZE GRADUALLY TO MINIMIZE TURBULENCE.

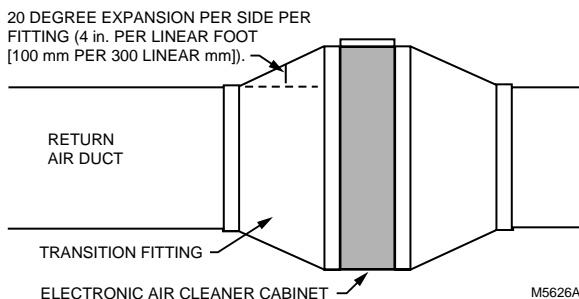

Fig. 4. Change duct size gradually to minimize turbulence.

Turning Vanes

If the air cleaner is installed close to an elbow or angle fitting, install turning vanes inside the angle to distribute airflow more evenly across the face of the cell. See Fig. 5.

Offsets

If the duct connection to the furnace in a side installation allows less than 7 in. (178 mm) for mounting the air cleaner cabinet, add an offset to the elbow. See Fig. 5.

TYPICAL USE OF DUCT OFFSET TO ALLOW SPACE FOR ELECTRONIC AIR CLEANER.

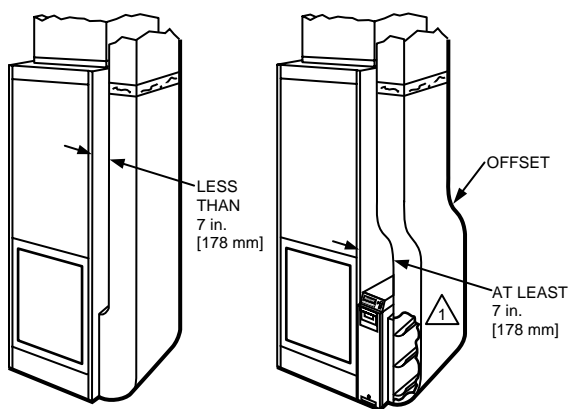

⚠ TURNING VANES HELP DISTRIBUTE AIRFLOW EVENLY.

Fig. 5. Typical use of duct offset to allow space for electronic air cleaner.

INSTALLATION

When Installing this Product...

1. Read these instructions carefully. Failure to follow them could damage the product or cause a hazardous condition.
2. Check the ratings given in the instructions and on the product to make sure the product is suitable for your application.
3. Installer must be a trained, experienced service technician.
4. After installation is complete, check out product operation as provided in these instructions.

⚠ WARNING

Electric Shock Hazard.
Can cause electrical shock or equipment damage.
 Do not connect to power before installation is complete.

Unpack Electronic Air Cleaner

- Check that all components are included. The electronic air cleaner is shipped assembled. The unit consists of a galvanized steel cabinet, power supply with on-off switch and neon light, one or two electronic cells and prefilters, access door with test button, and homeowner literature package.
- Order W8600F (optional), mounting hardware and installation literature separately.

Clean Blower Compartment

- Remove and discard the existing furnace filter.
- Thoroughly clean the blower compartment.
- If possible, power vacuum the ductwork to remove accumulated dust in an existing home, or construction dirt in a new home. The electronic air cleaner cannot remove dust that has settled in the blower compartment and distribution ducts.
- Check the edges of the furnace fan blades for dirt buildup and clean as necessary. The fan will not deliver the rated cfm if the blades are dirty.

Fasten Cabinet To Furnace

NOTE: This procedure shows a side installation on a typical highboy furnace. You may need to alter the procedure to fit your application.

- Remove and set aside the access door, electronic cells and prefilters.
- Align the cabinet with the return air opening.
- Create opening in furnace to match air cleaner cabinet opening.
- Install a transition when the furnace and air cleaner openings are different sizes. See Fig. 4.
- Place blocks under the cabinet so the unit is firmly supported and level. The 5/8 in. (16 mm) mounting foot on the cabinet hinge plate provides the minimum clearance required for the access door hinge.

- Attach the cabinet securely to the furnace. The unit can be attached directly, as shown, or a starting collar can first be fitted in the furnace opening. Either drill holes and fasten with sheet metal screws or rivets, or use slip joints. See Fig. 6.

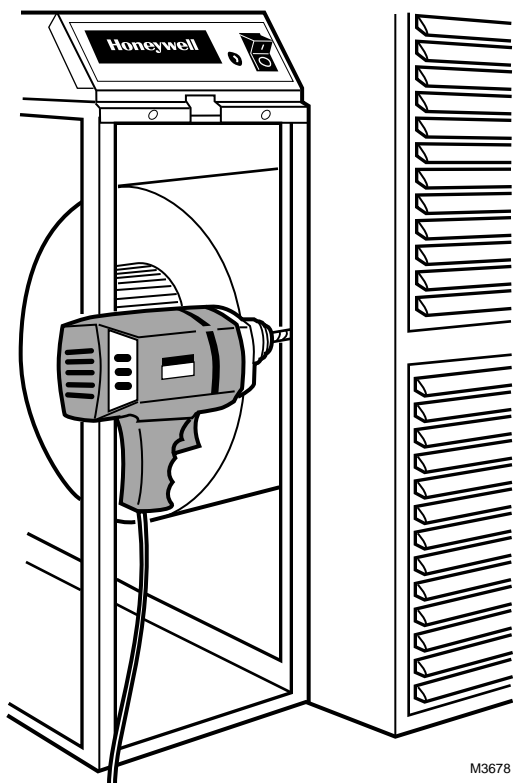

Fig. 6. Fasten cabinet to furnace.

Install Turning Vanes

- Mount turning vanes inside the elbow or angle fitting that is directly against the air cleaner cabinet.

Fasten Cabinet To Ductwork

- Install a transition when the opening in the air cleaner cabinet and the duct are different sizes. See Fig. 4.
- Fasten the other side of the cabinet to the elbow using sheet metal screws, rivets, or slip joints as appropriate. If drilling holes, use locking pliers to help hold the unit in place during drilling. See Fig. 7.

Install Optional W8600F Air Cleaner Monitor

Choose a location for the W8600F when it is part of the installation. The monitor is designed to mount next to the thermostat, or in any convenient visible area (such as utility room) where it can be seen as it monitors the air cleaner performance. It shares no electrical connections with the thermostat. To install, see Fig. 8 and refer to the Installations Instructions, form 69-1200, included with the monitor.

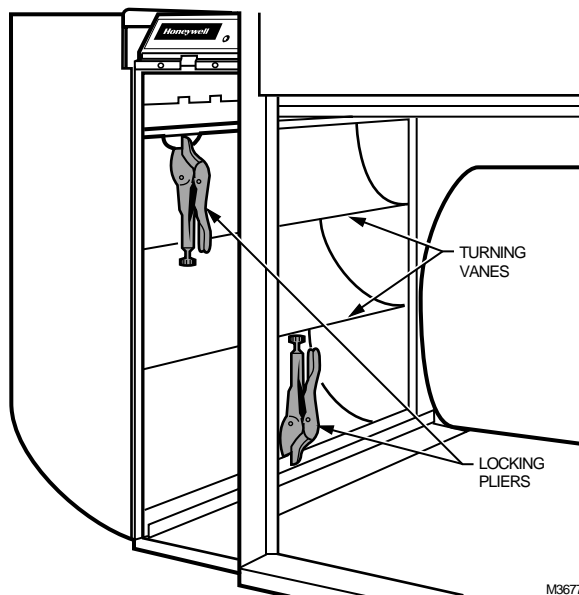

Fig. 7. Connect ductwork to air cleaner. Note turning vanes. Locking pliers hold duct to air cleaner cabinet during installation.

The W8600F Air Cleaner Monitor is an option available for use with the F58F. The series two F58F requires a solid state power supply that is compatible with the W8600F driver board. Any series one F58 can be upgraded to use the W8600F when the power supply is replaced and the driver board (included in W8600F kit) is installed.

The W8600F function indicator panel has four liquid crystal display (LCD) arrowheads that point to ON, BATTERY, SERVICE or FAULT. See Fig. 8. The arrowheads darken to indicate the existing EAC condition. See Table 1.

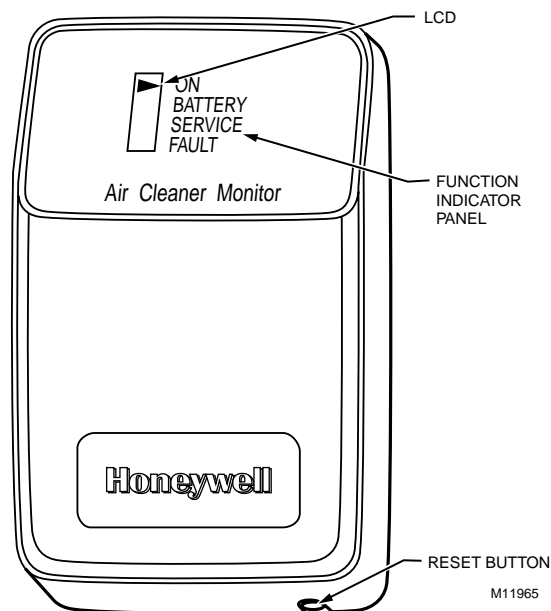

Fig. 8. W8600F Air Cleaner Monitor features.

Location

The styling of the W8600F is designed to blend with the latest T8600 family of Honeywell Chronotherm® IV Deluxe Programmable Thermostats. A special mounting template is included for mounting next to the T8600. The W8600F can also be mounted at any other convenient location in the living area or equipment room.

NOTE: The W8600F shares no common electrical connections with the thermostat.

Table 1. Description of W8600F Function Indicator Panel.

Indicators	Condition
ON	EAC is powered and system blower is running.
BATTERY	Battery that maintains W8600F memory is low and needs to be replaced.
SERVICE	EAC prefilter and cells need to be washed ^a .
FAULT	<ul style="list-style-type: none"> Shorting of collector plates. Continuous ionizer or collector plate arcing. Power supply failure. Excessive current. Major reduction in high voltage. EAC prefilter and cells are past SERVICE level of dirt and need to be washed immediately. Call a service technician.

^a The reset button is located on the bottom of W8600F. After the prefilters and cells are cleaned and reinstalled, press this button to turn off the SERVICE indicator and reset the wash frequency timer.

Mounting

The following mounting instructions assume that the W8600F is mounted next to a T8600 Thermostat. If installing the monitor at another location, modify the procedure to fit the installation.

1. Hold the mounting template (included in the bag assembly) next to the T8600 as shown in Fig. 9.
2. Mark the holes for the screw anchors and the 3-conductor thermostat cable.
3. Remove the template and drill the holes.
4. Remove the W8600F from the base.

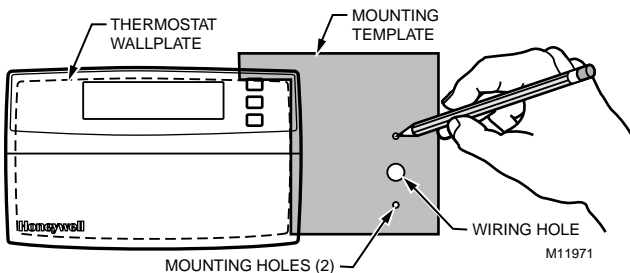

Fig. 9. Positioning mounting template.

5. Position the W8600F base over the holes and install the anchors and screws. Tighten the screws until the base is mounted firmly on the wall.

Select Wash Frequency

Use the W8600F DIP switches to program the time between SERVICE indications. Be sure to select the setting according to the conditions of the home. Factors to consider include the duty cycle of the EAC, the number of people and pets, and activities such as woodworking and other crafts that are being done in the home.

Refer to Table 2 to select the wash frequency. Set the W8600F DIP switches to match the selection. See Fig. 10. The time listed represents actual run time of the EAC, not calendar days.

Table 2. Wash Frequency Options.

DIP Switch Settings			Wash Frequency (Days)
F1	F2	F3	
Off	Off	Off	10
Off	Off	On	20
Off	On	Off	30
Off	On	On	40
On	Off	Off	50
On	Off	On	70
On	On	Off	100
On	On	On	180

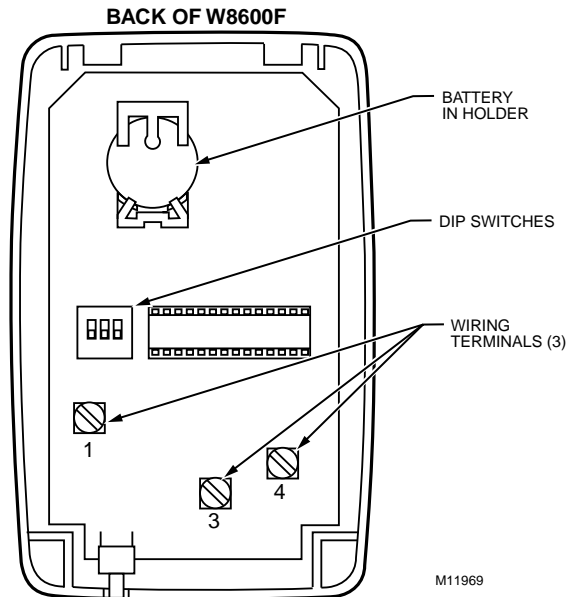

Fig. 10. Back of W8600F.

Wiring

1. Run a 3-conductor thermostat cable (up to 18 gauge) from the W8600F to the terminal strip on the air cleaner.

IMPORTANT

Connect cable to W8600F before attaching to the air cleaner terminals to minimize the risk of damage due to static electricity.

2. Connect the wires to terminals 1, 3 and 4 on the W8600F. See Fig. 10.
3. Check that the battery is correctly installed in the W8600F battery holder.
4. Snap the W8600F onto the base.
5. Turn off the power for the EAC.

⚠ WARNING

Electric Shock Hazard.
Can cause electrical shock or equipment damage. Disconnect EAC power and open the access door before opening the power supply box cover.

6. Open the power supply box cover.
7. Remove the plug from the side of the power supply box (plug can be a metal knockout or a blank terminal strip).
8. Install the terminal block/cable assembly supplied with W8600F kit.
9. Plug the connector on the end of the cable assembly into the J2 terminal on the driver board (included with W8600F kit). See Fig. 11.

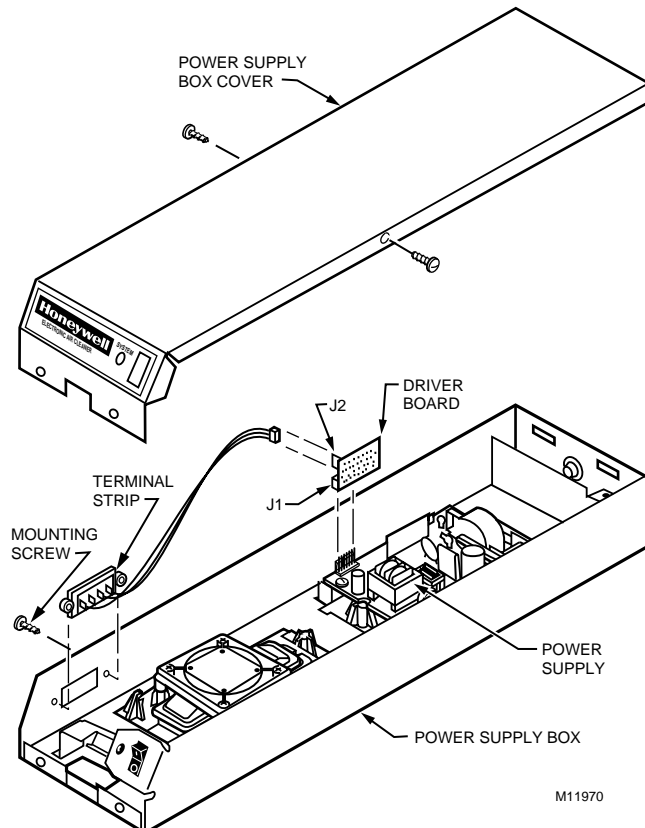

Fig. 11. Installing the driver board on the EAC.

10. Plug the driver board assembly into the J1 power supply connector.
11. Replace the power supply box cover.
12. Connect the three wires from the W8600F to the EAC terminals 1, 3 and 4. See Fig. 12.

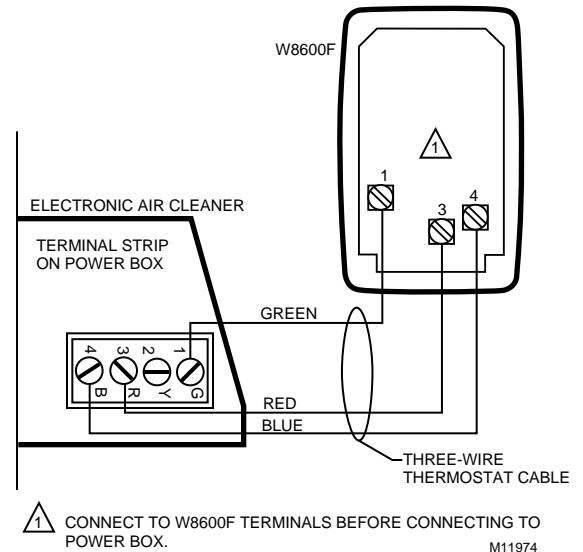

Fig. 12. Wiring W8600F to F58F power box terminal strip.

NOTE: Connect terminal 1 to 1, 3 to 3 and 4 to 4.

13. Turn on the EAC power.
14. Turn on the system fan.
15. Push the W8600F reset button. All four indicators on the display will flash 5 times. The ON indicator will stay active as long as the EAC is on. See Fig. 13.

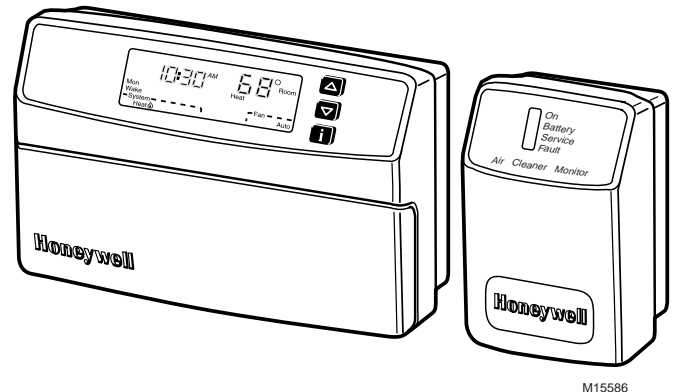

Fig. 13. Complete T8600/W8600F installation.

Seal Joints

- ❑ Seal all joints in the return air system between the air cleaner and the furnace to prevent dust from entering the clean airstream. Use optional air cleaner cabinet gasket kit (part #32002109-001). Plastic or foil tape.

Disable Unused Prefilter Guide

- ❑ Crimp the end of the downstream (closest to the furnace) prefilter guide to prevent incorrect prefilter installation following cleaning. See Fig. 14.

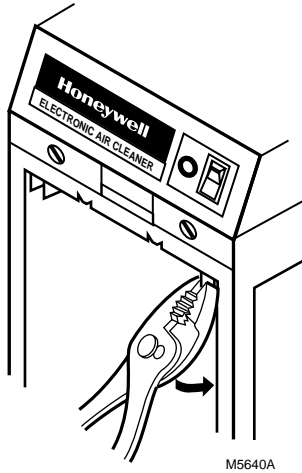

Fig. 14. Crimping prefilter guide.

Position Cell Key

The electronic cell must always be installed so the ionizer section is on the upstream side. A factory-installed cell key on the bottom of the cabinet allows the cell to be inserted in only one direction. If the arrow molded into the plastic key points in the same direction as the airflow, the ionizer will always be on the upstream side.

If the position of the key must be reversed, proceed as follows:

1. Remove the electronic cell.
2. Remove the screw holding the cell key in place. See Fig. 15.

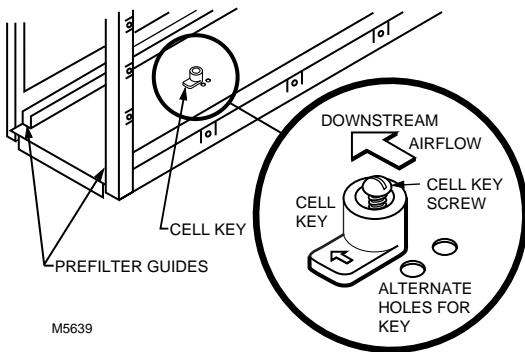

Fig. 15. Position of cell key determines orientation of cell (arrow on key must point downstream).

3. Turn the key around and place it over the opposite holes. The tab on the bottom fits into the larger hole, and the screw fits into the smaller hole. Make sure the arrow on the key points in the direction of the airflow (downstream).
4. Tighten the screw into the new hole.
5. Insert the electronic cell. The ionizer section will now be on the air-entering (upstream) side of the cabinet.

Attach Cell Handles

The cell handles are attached to the packing insert inside the access door. They must be installed on the end of the cell closest to the access door. To install:

1. Orient the cell as it will be when installed. The gray contact board must be up and the airflow arrow stamped into the cell must point downstream.
2. Hold the handle sideways and insert the solid tab on the back of the handle into the slot in the cell. Turn the handle 90 degrees clockwise to align the divided tab with the square hole. See Fig. 16.

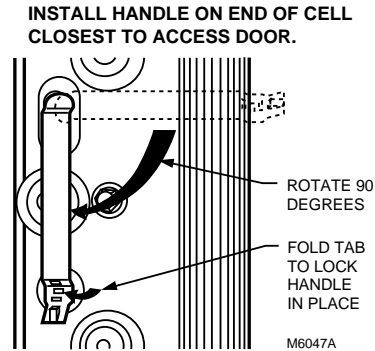

Fig. 16. Install handle on end of cell closest to access door.

3. Insert the divided tab into the square hole.
4. Fold up the wedge and insert it into the divided tab to lock the handle in place. If necessary, press with a blunt instrument like the end of a pliers.

Reassemble Air Cleaner

- Insert the electronic cell with the gray contact board up and the airflow arrow pointing downstream. If the cell does not slide easily into the cabinet, check the orientation of the cell key.
- Insert the prefilter on the upstream side of the cabinet in the guide provided.
- Replace the access door. Insert the tab on the bottom of the door into the slot in the cabinet, then swing it closed and press into place. The door must be firmly in place or the air cleaner will not operate.

Complete Wiring

⚠ WARNING

Electric Shock Hazard.
Can cause personal injury.
Do not use an extension cord.

- Assure all wiring complies with local codes and ordinances.
 - The line voltage power source must match the voltage and frequency printed on the label inside the access door.
 - When the system fan comes on the Airflow Switch (AFS) senses the negative pressure in the duct and turns the power supply on. If power to the air cleaner is controlled by another switch the AFS can be disabled by cutting the humper on the back of the AFS circuit board. See Fig. 17.
- Plug the electronic air cleaner directly into the correct voltage and frequency outlet. See Fig. 17 for internal schematic. The air cleaner will operate properly with any fan when wired with conduit or plugged in.

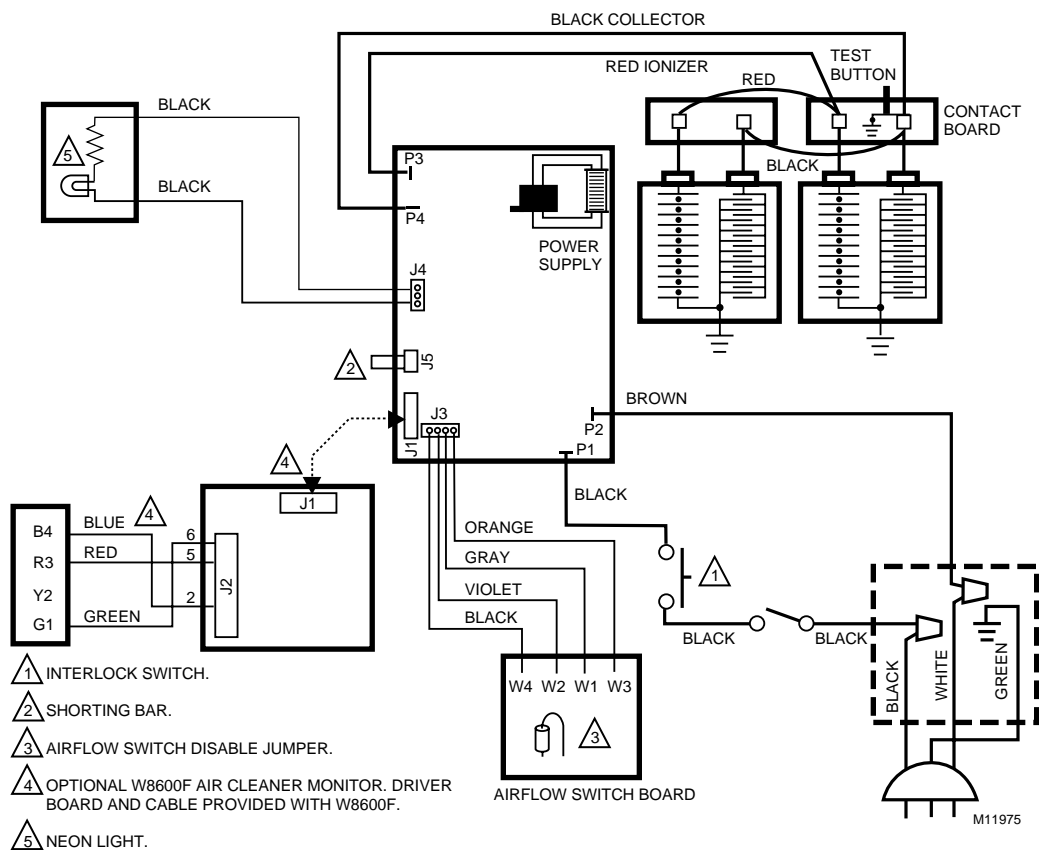

Fig. 17. Internal schematic for electronic air cleaner with W8600F.

NOTE: To reduce the risk of electric shock, this product has a grounding type plug that has a third (grounding) pin. This plug will only fit into a grounding type power outlet. If the plug does not fit into the outlet, contact a qualified electrician to install the proper outlet. Do not change the plug in any way.

- Alternatively, the electronic air cleaner can be wired with conduit.
 1. Open access door.
 2. Remove and retain the (2) screws from the front of the power box and the (2) screws from the sides of the power box. See Fig. 18.
 3. In the power box, remove and retain (2) wire nuts that connect the line cord leads to the power box wiring.
 4. Remove the power cord green lead from the green grounding screw on the wiring compartment barrier.
 5. Remove the power cord and the strain relief.
 6. Install the plug (provided with the literature pack) in the hole left by the power cord.
 7. Attach conduit through a power box side knockout.
 8. Wire the air cleaner directly to line voltage using wire nuts. See Fig. 19. Secure ground connection to the green ground screw on the wiring compartment barrier.
 9. Replace power supply cover and access door.

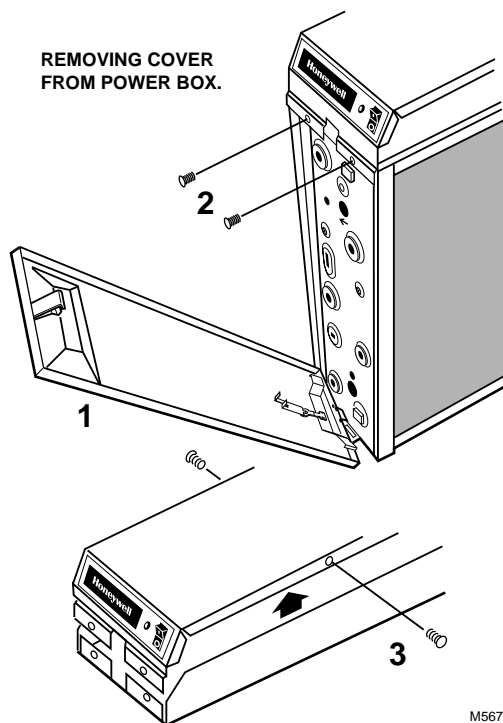

Fig. 18. Removing cover from power box.

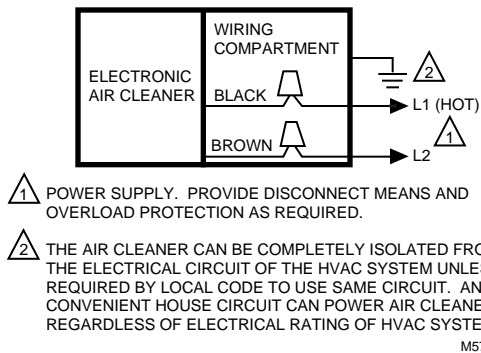

Fig. 19. Conduit connection for electronic air cleaner.

OPERATION

Large particles (lint, hair) are caught by the prefilter. As the dirty air passes through the intense high voltage electric field surrounding the ionizer wires, all particles are given an electrical charge. The air then moves through the collector part of the cell where alternate parallel plates are charged positively and negatively, creating a uniform electrostatic field. The charged particles are attracted to and collect on the plates that have the opposite electrical charge. The air leaving the air cleaner has fewer particles. Each time the air circulates through the F58F, more particles are removed.

CHECKOUT

Inspect the Installation

Make sure:

- Turning vanes and transitions, as needed, are properly installed.
- Sheet metal joints between air cleaner and furnace are sealed.
- All sheet metal connections are complete.
- Original furnace filter has been removed and the blower compartment cleaned.
- If atomizing humidifier is installed upstream from the air cleaner, a disposable furnace filter is installed between the humidifier and the air cleaner.
- Outside air, if used, is mixed with return air or heated, as necessary, before it can reach the air cleaner.
- Airflow arrows on the electronic cell point downstream.
- Prefilter is on the upstream side of the cell.
- Cell handle faces outward.
- Electronic cell and prefilter are clean and dry.
- W8600F (if included) wiring connections are properly made.

Check Air Cleaner Operation

With all components in place, turn on the air cleaner switch and energize the system blower. Check the following points of operation:

1. The neon light next to the on-off switch is on. If a W8600F is part of the installation, also check the wall panel and make sure the ON indicator is lit. The W8600F FAULT indicator will come on if there is a problem with the high voltage power supply.

2. Turn off the system blower. The neon light should go off after a few seconds. The neon light shows that the air cleaner is energized and the high voltage power supply is working properly.
3. Turn on the system blower. With the air cleaner energized, push the test button. A snapping sound indicates that the collector voltage is present on the cell. The W8600F FAULT indicator will come on when the test button is held down.
4. With a multispeed blower, repeat steps 1 through 3 for each fan speed.
5. If operation is not as described, refer to the Troubleshooting section.

SERVICE

CAUTION

Sharp Edges.

Can cause personal injury.

Carefully handle the cells or wear protective gloves to avoid cuts from the sharp metal edges.

Cleaning the Cells and Prefilters

To assure optimum performance from the air cleaner, the cells and prefilters must be cleaned regularly—every one to six months. Washing frequency will vary depending on the number of family members, pets, activities (such as cooking or woodworking) and smoking habits. Use the wash reminder schedule provided with the air cleaner to help establish and maintain a regular cleaning schedule. Mount the wash reminder schedule in a convenient location.

If the air cleaner has a W8600F Air Cleaner Monitor the SERVICE indicator will activate to indicate that it is time to wash the prefilters and cells. The time between activation of the SERVICE indicator is based on air cleaner run time that is selected by the installer at installation. See page 8 for instructions on selecting air cleaner run time. Pressing the Reset button on the bottom right corner of the housing resets the W8600F SERVICE indicator, see Fig. 8.

NOTE: To let the heating or air conditioning system operate normally while the cells are being washed, simply turn off the air cleaner switch.

Vacuum the prefilter or brush, or soak it in a tub. Do not wash the prefilter in the dishwasher or car wash.

Automatic Dishwasher

CAUTION

Burn Hazard.

Can cause personal injury.

Allow the cells to cool completely in the dishwasher at the end of the wash cycle or wear protective gloves to avoid burns. Hot water can accumulate in the tubes supporting the collector plates. Tip the cells so these tubes will drain.

IMPORTANT

- Check the dishwasher owner's manual. Some manufacturers do not recommend washing electronic cells in their dishwashers.
- If the dishwasher has upper and lower arms, position the cells carefully to allow good water circulation.
- Be careful to avoid damaging the cells when placing them in the dishwasher. Broken ionizer wires or bent collector plates are not included in the warranty.
- Very dirty cells, especially from tobacco or cooking smoke, can discolor the plastic parts and the lining of some dishwashers. This discoloration is not harmful. To minimize it, wash the cells more frequently or try a different brand of detergent.
- Do not allow the dishwasher to run through the dry cycle. This will bake on any contaminants not removed during the wash cycle and reduce air cleaner efficiency.

1. Put the cells on the lower rack of the dishwasher with the airflow arrow pointing up. It may be necessary to remove the upper rack. Do not block water flow to the upper arm.

HINT: Lay a few large water glasses between the spikes on the lower rack and rest the cells on them so the spikes do not damage the aluminum collector blades.

2. Using regular dishwashing detergent, allow the dishwasher to run through the complete wash and rinse cycle. Do not use the dry cycle. To avoid burns, let the cells cool completely before removing, or wear protective gloves when removing the cells. Remember that water may be trapped inside the cells. Tip the cells so the tubes can drain.
3. Wipe the ionizer wires and contact board on the end of the cell using thumb and forefinger with a small, damp cloth.
4. Inspect the dishwasher. Rerun the wash and/or rinse cycle with the dishwasher empty if there is dirt or residue from washing the cells. If dirt or residue seems excessive, wash the cells more often or try a different detergent.

Washing the Cells in a Container



CAUTION

Hazardous Chemical.
Can cause personal injury.

- Do not splash the detergent solution in eyes. Wear rubber gloves to avoid prolonged detergent contact with skin.
- Keep detergent and solution out of reach of children.

NOTE: Always wash the cells first, then the prefilters, to keep heavy prefilter lint from getting caught in the cells.

1. Use a large enough container, such as a laundry tub or trash container, to hold one or both cells.

NOTE: Sharp corners on the cells can scratch the surface of a bathtub.

2. Dissolve about 3/4 cup of automatic dishwasher detergent per cell in enough hot water to cover the cells. If the detergent does not dissolve readily, or forms a scum on the water, try another brand, or use softened water.
3. After the detergent has completely dissolved, place the cells in the container and let soak for 15 to 20 minutes. Agitate up and down a few times, and re-move. See Fig. 20.

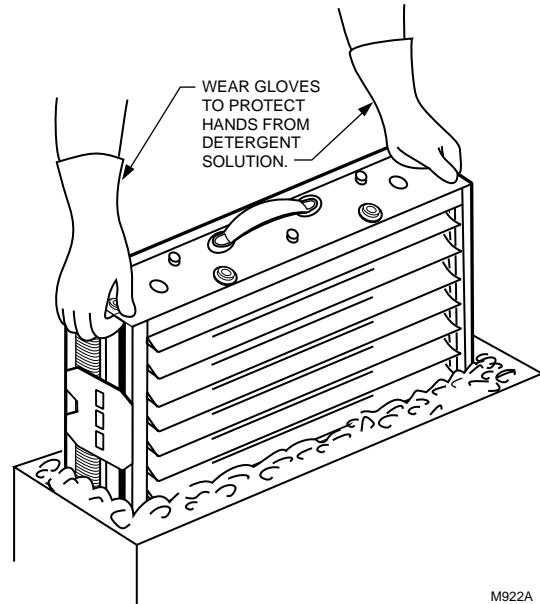

Fig. 20. Washing cells in container.

4. Next, wash the prefilters the same way. Empty and rinse the wash container.
5. Rinse the cells and prefilters with a hard spray of very hot water; rinse the tub clean, then fill the tub with clean hot water and soak for 5 to 15 minutes. Rinse until the water draining from the cells and prefilters no longer feels slippery.
6. Soak cells and prefilters in a final clear water rinse for ten minutes.
7. Wipe the ionizer wires and contact board on the end of the cell using your thumb and forefinger with a small, damp cloth.

Washing the Cells at Car Wash

Use the hand sprayer at a coin-operated do-it-yourself car wash to clean the cells. Hold the nozzle at least two feet away from the unit to avoid damage (such as broken ionizer wires or bent collector plates) from the high pressure stream of water. See Fig. 21. Follow the same sequence of wash and rinse as recommended for cars. However, do not wax the cells. Be sure to rinse until the water draining from the cells no longer feels slippery.

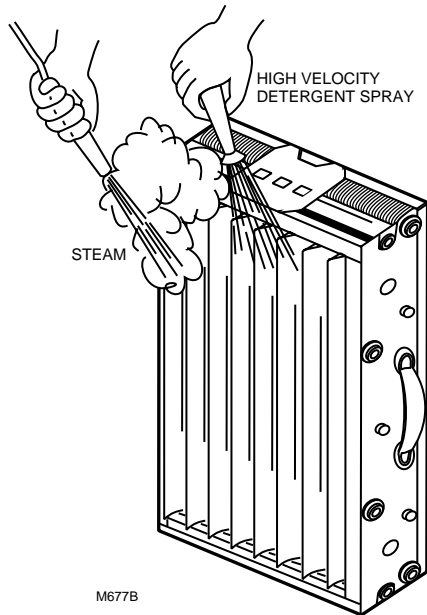

Fig. 21. Washing cells at car wash.

Reinstall the Cells and Prefilters

1. Inspect the cells for broken ionizer wires and bent collector plates. Repair as necessary or take to a Honeywell Authorized Air Cleaner Repair Station.
2. Slide the prefilters into the upstream prefilter guides.
3. Slide in the air cleaner cells so the airflow arrow points downstream and the handles faces outward.
4. Firmly close the access door.
5. Turn on the air cleaner. If the cells and prefilters are wet, the neon light may not come on and you may hear arcing. If the arcing is annoying, simply turn off the air cleaner for two to three hours or until the cells is dry.

If the air cleaner has a Remote Performance Indicator, the FAULT indicator may activate when the cells and prefilters are wet. Again, if the FAULT indicator is annoying, simply turn off the air cleaner for two to three hours or until the cells and prefilters are dry.

Replacing Ionizer Wires

Broken or bent ionizer wires can cause an electrical short to ground, often resulting in visible arcing or sparking. Do not use cells until broken wires are removed. Cells can be used temporarily with one wire missing, but replace the wire as soon as possible.

Replacement wires are supplied cut to length with eyelets on both ends for easy installation. To install:

1. Hook the eyelet on one end of the wire over the spring connector on one end of the cell. See Fig. 21. Be careful to avoid damaging the spring connector or other parts of the cell.

2. Hold the opposite eyelet with a needlenose pliers and stretch the wire the length of the cell. Depress the opposite spring connector and hook the eyelet over it.
3. Check the cell for short circuits using an ohmmeter. Check the resistance between the frame of the cell and both the ionizer and the collector contacts. In each case, the resistance should be infinite. See Fig. 22.

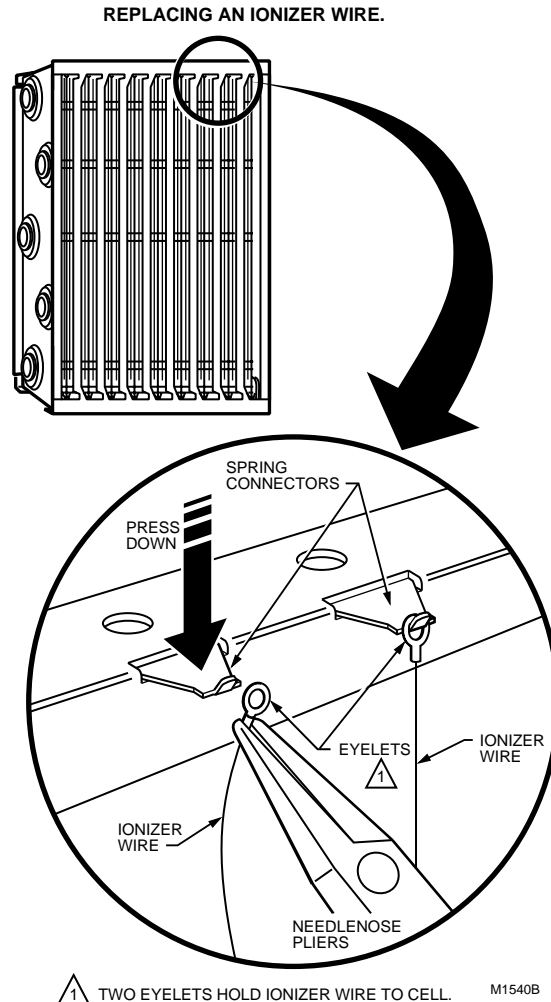

Fig. 22. Replacing an ionizer wire.

Modification to Reduce Ozone Odor

WARNING

Electric Shock Hazard.

Can cause personal injury.

Always disconnect power and open the access door before opening the power supply cover.

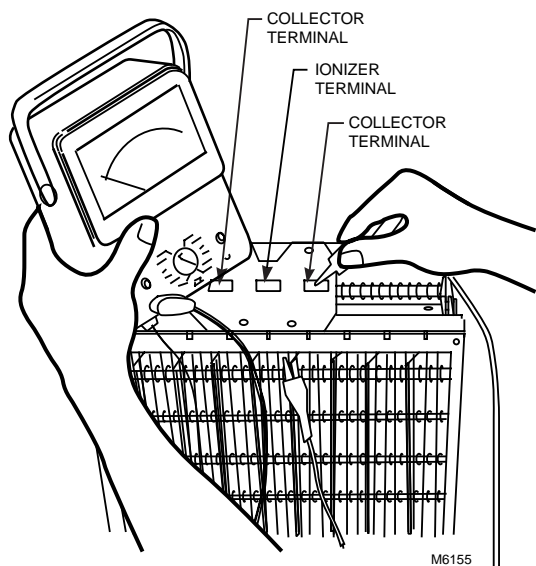

Fig. 23. Use ohmmeter to check electronic cells for short circuits.

The electronic air cleaner generates a small amount of ozone in normal operation. During the first week or two of operation, the amount may be higher because of sharp edges on some of the new high voltage metal parts. Normal use quickly dulls these edges.

The average person can detect the odor of ozone in concentrations as low as 0.003 to 0.010 parts per million (ppm). The electronic air cleaner contributes 0.005 to 0.010 ppm of ozone to the indoor air. The U.S. Food and Drug Administration and Health and Welfare Canada recommend

that indoor ozone concentration should not exceed 0.050 ppm. As a comparison, the outdoor ozone level in major cities is sometimes as high 0.100 ppm.

However, if desired, the ozone generated by the air cleaner can be reduced in one of two ways:

1. Install an activated carbon filter downstream from the air cleaner. Make sure particles from the air filter cannot fall into the air cleaner.

⚠ WARNING

Electric Shock Hazard.

Can cause personal injury.

Only a trained service technician should perform the following procedure.

2. This will reduce ozone production about 20 to 25 percent and reduce efficiency about seven to ten percent, depending on actual airflow delivered by the furnace blower.
 - a. Unplug or disconnect power supply to the air cleaner.
 - b. Open the access door.
 - c. Remove the power box cover. See Fig. 24.
 - d. Locate J5 shorting bar on the power supply. See Fig. 25. Remove the shorting bar and reinstall on only one pin.

NOTE: The ozone will be reduced, but the shorting bar is available for reinstallation if needed.

- e. Replace the power supply cover and access the door. Turn on the power.
- f. Repeat the checkout procedure before leaving the job.

REMOVE POWER BOX FROM AIR CLEANER AND REMOVE THE COVER.

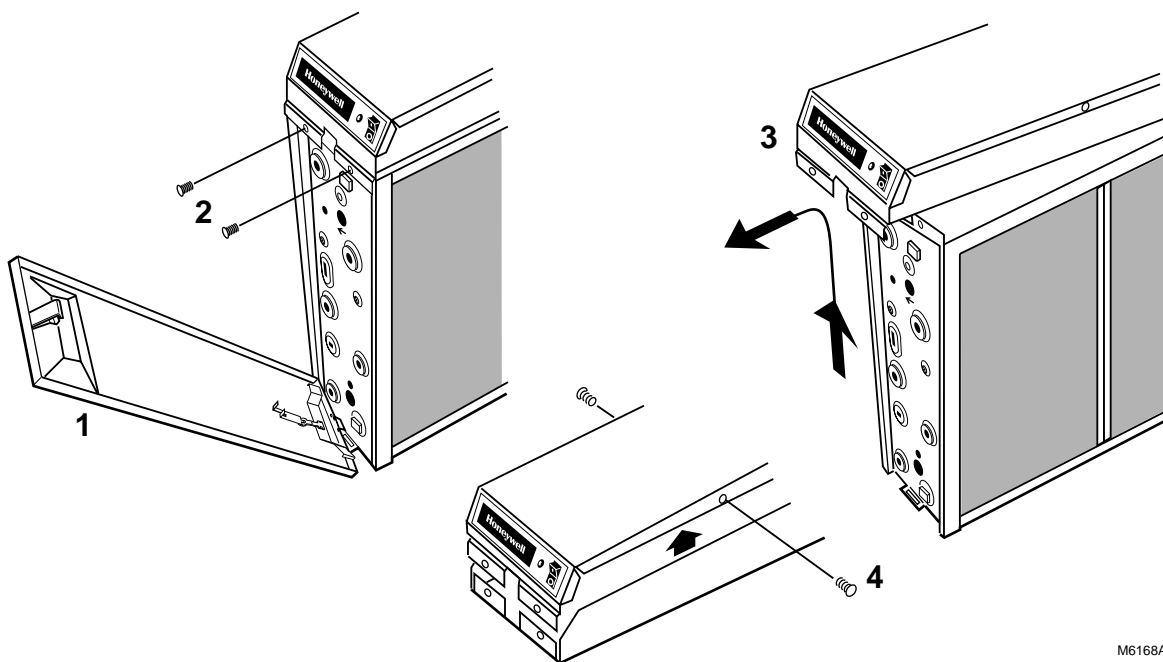

Fig. 24. Remove power box from air cleaner and remove cover.

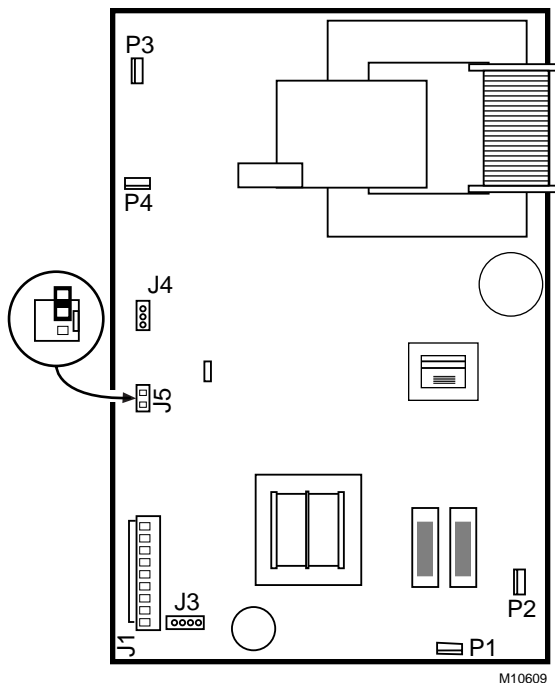

Fig. 25. Move J5 shorting bar to reduce ozone production about 20 to 25 percent.

ELECTRICAL TROUBLESHOOTING

⚠ WARNING

Electric Shock Hazard.
Can cause personal injury or equipment damage.
 The following procedures expose hazardous live parts. Disconnect from power between checks and proceed carefully. These instructions are for use by qualified personnel only .

Tools and Equipment

- Troubleshooting the electronic air cleaner requires:
- Needle nose pliers for stringing ionizer wires and inserting edge connectors.
 - Test meter.

Neon Light (On Power Box)

The neon light is powered through the power supply and is on when the power supply output voltage is normal.

Test Button

When pushed, the test button shorts from collector voltage to ground. The resulting arcing sound indicates that high voltage is being supplied to the collector. The solid state power supply controls current flow to the collector. On air cleaners with a W8600F, the FAULT indicator will activate when the test button is held down.

FAULT Indicator (Air Cleaners with W8600F)

The FAULT indicator is on the W8600F. It activates to indicate the following problems: excessive dirt loading partial shorting of the collector, continuous ionizer or collector arcing, power supply failure, excessive ionizer current, or any condition causing a major reduction in high voltage.

Power Box

⚠ WARNING

Electric Shock Hazard.
Can cause personal injury.
 Always turn off power and remove access door before removing power supply or its cover.

The solid state power supply within the power supply box can be replaced. When troubleshooting indicates a power supply or solid state performance indicator problem, replace the entire power box or replace the power supply within the box. See Installation Instructions, form 69-1136. See Fig. 24 for power box removal.

Troubleshooting Procedure

The electronic air cleaner Troubleshooting charts show how to quickly isolate a problem in the air cleaner. Although a meter is needed for some steps, the primary diagnostic tools are the neon light and the test button. See Fig. 26.

REPLACEMENT PARTS/EXPLODED VIEW

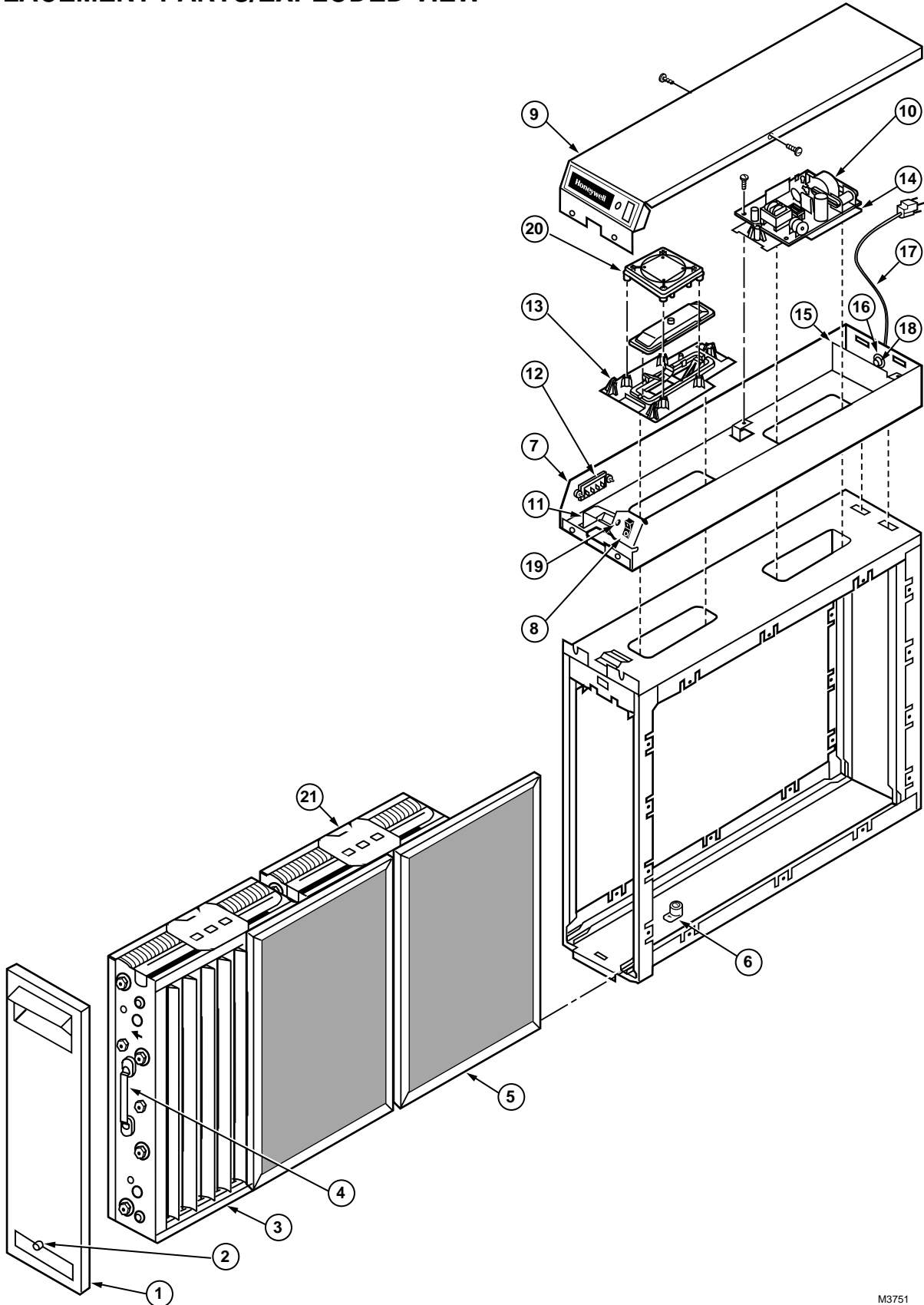

M3751

Fig. 27. Components of the F58F Electronic Air Cleaner.

No.	Description	Nominal Return Air Opening 20 x 25 in. (508 x 635 mm)
1	Access Door includes #2	203305AB (1)
2	Test Button Assembly	137980A (1)
3	Electronic Cell	FC37A1064 (2)
4	Cell Handle	137266 (2)
5	Prefilter	203372 (2)
6	Cell Key	136518 (1)
7	Power Box Assembly Includes #8-#20, 120V, 60 HZ	208417A (1)
8	Switch	203321 (1)
9	Power Box Cover and Label	203318A (1)
10	Power Supply, 120V, 60 Hz	208414A (1)
11	Interlock Bracket and Switch	4074ETG (1)
12	W8600 Terminal Strip	Supplied with W8600F
13	Terminal Board Assembly Front	203329B (1)
14	Terminal Board Assembly Rear	203329A (1)
15	Barrier Plate	203331 (1)
16	Strain Relief	203852 (1)
17	Line Cord	4074ETD(1)
18	Hole Plug	203847(1)
19	Neon Assembly	4074EYS (1)
20	Airflow Switch	4074ETH (1)
21	FC37 Bag Assy for cell repair Contains 2 Connector Clips, 1 Terminal Board and Instruction Sheet	4074EHG

Parts and Accessories Not Illustrated

Description	Nominal Return Air Opening 20 x 25 in. (508 x 635 mm)
Ionizer Wires (multiples of 5)	136434AA
Mounting Screws	136375 (6)
Air Cleaner Monitor (beige color)	W8600F1006
Premier White® Air Cleaner Monitor	W8600F1014

Home and Building Control

Honeywell Inc.
Honeywell Plaza
P.O. Box 524
Minneapolis MN 55408-0524

Honeywell Latin American Region

480 Sawgrass Corporate Parkway
Suite 200
Sunrise FL 33325

Home and Building Control

Honeywell Limited-Honeywell Limitée
155 Gordon Baker Road
North York, Ontario
M2H 3N7

Honeywell Europe S.A.

3 Avenue du Bourget
1140 Brussels
Belgium

Honeywell Asia Pacific Inc.

Room 3213-3225
Sun Hung Kai Centre
No. 30 Harbour Road
Wanchai
Hong Kong

Honeywell

